

General Purpose Engine

GCV160A

(TYPE S3A)

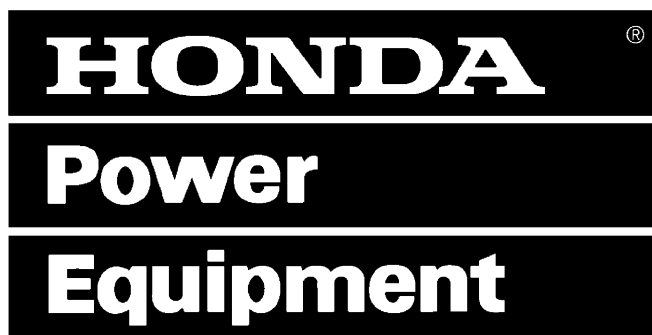

Parts Catalog

AUGUST, 2006

American Honda Motor Co., Inc.

TABLE OF CONTENTS

Introduction

Grid / Page

- HOW TO USE THIS CATALOG A2 4
- SERIAL NUMBERS A3 6
- BULK HOSE PART NUMBER PATTERN..... A3 7
- MASTER INDEX A4 8

Part Groups

- ENGINE SECTION 1-C1 1-1

Index

- PART NUMBER INDEX B1 2-1
- DESCRIPTION INDEX 1-D1 3-1

HOW TO USE THIS CATALOG

CATALOG/CATALOGUE PAGE BREAKDOWN (Generic layout-sample data only)

MODEL		TYPE								(11)
A = MODEL		a=TYPE								B-1
B = MODEL		b=TYPE								
C = MODEL		c=TYPE								
(4)										
Ref	Description	(3) Mod	(6) Type	Engine Serial Number		ORG	QTY	Part Number	H/C	
1	COVER SET, CYLINDER HEAD	4	b	15240057	-----	JPN	1	12310-PE2-020	2031797	
	COVER SET, CYLINDER HEAD			-----	12234811	USA	1	12310-PE2-030	2210888	
(1)	(2)			(5)		(7)	(8)	(9)	(10)	

KEY TO CATALOG/CATALOGUE PAGE BREAKDOWN

1. **Ref** - Reference numbers correspond to the reference numbers on the illustrations. All illustrations are representative only, and do not necessarily look exactly like the actual part. "N1" signifies the part is not illustrated. Reference numbers may be skipped when they apply to other models.

2. **Description*** - Describes the part for the related part number.

Abbreviations:

ASSY. - Assembly	A.C. - Alternating Current
L(100L) - Link(100Links)	D.C. - Direct Current
R. - Right	KPH - Kilometers Per Hour
L. - Left	MPH - Miles Per Hour
IN. - Inlet	A.M. - Attaching Mark
EX. - Exhaust	T.M. - Transcript Mark
FR. - Front	A - Ampere
RR. - Rear	WL - With Labeling
HEX. - Hexagonal	WOL - Without Labeling
STD. - Standard	T (22T) - Tooth
MM - Millimeter	C.D.I. - Capacitive Discharge Ignition
G - Gram	G.F.C.I. - Ground Fault Circuit Interruptor
V - Volt	
W - Watt	

3. **Mod*** - Model alpha labeling is unique per catalog/catalogue (not consistent with other catalogs/catalogues).

4. Each model and type in the catalog/catalogue is represented by an alpha label.

5. **Serial Number** - Applies to Engine or Frame serial numbers depending on the section. The serial numbers of a unit (frame, engine, carburetor) should be checked prior to ordering parts for the unit. In cases where a part has been modified, the beginning and/or ending serial number of the unit bearing the modification is listed in the "SERIAL NUMBER" column. Modification parts can be controlled by three types of numbers as described below.

Engine serial number - Engine group parts (Block numbers beginning with "E").

Carburetor identification number - Carburetor component parts.

Frame serial number - Frame group parts (Block numbers beginning with "F").

Note 1 - A modification that does not follow the pattern above will be clarified by a comment located below the part description. A serial number chart and a guide to serial number locations are provided in the front portion of the catalog/catalogue.

Note 2 - Although most models will be identified by Engine and Frame serial numbers, some models may be identified by one serial number only - either Engine serial number or Frame serial number.

6. **Type*** - Model Type is defined in the serial number chart.

7. **ORG*** - Manufacturing country of origin of the unit.

8. **QTY** - Quantity required for the specified Block/Section.

A. "AR" in place of the quantity indicates AS REQUIRED.

B. "(" Parentheses in the quantity indicate "optional".

9. **Part Number** - Part number corresponds to the reference number and application. Several part numbers may be listed under one (1) reference number.

Note: For U.S. only - For your convenience the current supersede chain, as of print date, has been listed. Supersede chains are subject to change without notice.

10. **H/C** - The Honda Code and Part Number share a 1 to 1 relationship (U.S.A. only).

11. The Block Number identifies the catalog/catalogue section.

CONSTRUCTION OF PART NUMBERS

All parts are classified into two groups, "GENERAL PARTS" and "STANDARD PARTS". All parts are numbered according to the system described below:

General Parts

Example: Driver Seat Assembly Part No.	77400-634-671ZA
Function No.	77
Component No.	400
Model Code No.	-634-
Modification Process Design	671
Color/colour Indicator**	ZA

Standard Parts

Example: 8 x 18 Hex. bolt Part No.	92000-08018-0A
Function No.	92000
Dimensions	-08018-
ISO Standard Designation	0
Chemical Surface Treatment	A

**The color/colour indicator at the end of a part number signifies a color/colour. These color/colour indicators such as ZA, ZB, ZC . . . , except ZZ, do not identify the actual color/colour. Actual colors/colours are identified by a code that appears between asterisks in the part description.

Additional Information - The section index located at the bottom of each microfiche grid lists section titles. The Engine and Frame sections have separate section indexes.

Some Block Titles are numbered, such as Air Cleaner (1), Air Cleaner (3), Muffler (2) or Muffler (4), etc. These may skip numbers when some blocks apply in other volumes of the same model(s).

*When columns become full, additional data is displayed on a second line.

SERIAL NUMBERS

Models and applicable serial numbers

Models and applicable serial numbers given in this parts catalog can be identified as follows.

Model	Type	Applicable Engine Serial No.	Applicable Frame Serial No.	Applicable Carburetor Identification
GCV160A	S3A	GJAEA-1000001~	—	BB62B A

BULK HOSE PART NUMBER PATTERN

Construction of Fuel and Vacuum Hose Part Number

Example: 9 5 0 0 1 - 7 5 0 0 1 - 4 0 M

Roll Hose

All roll hose part numbers have an "M" in this position

Appearance Code

Fuel Hose:

- 2 = Red, braided exterior
- 3 = Red
- 4 = Ash Gray with red stripe
- 5 = Black, braided interior
- 6 = Black

Vinyl Hose:

- 1 = Ash Gray
- 2 = Black
- 3 = Light Red
- 6 = Light Red
- 7 = Pale Black

Vacuum Hose:

- 1 = Ash Gray
- 2 = Ash Gray
- 3 = Black
- 5 = Black

Length

Cut Hose length is in *Millimeters (mm)*

Bulk Hose length is in *Meters (M)*

Inside Diameter

Fuel and Vacuum Hose

- | | |
|-----------------------|------------------------------|
| 35 = 3.5 mm | 11 = 11 mm |
| 45 = 4.5 mm | 91 = 12 (outside dia. 15) mm |
| 50 = 5.0 mm | 92 = 12 (outside dia. 16) mm |
| 55 = 5.3 mm or 5.5 mm | 12 = 12 (outside dia. 17) mm |
| 65 = 6.5 mm | 14 = 14 mm |
| 70 = 7.0 mm | 17 = 17 mm |
| 75 = 7.3 mm or 7.5 mm | |
| 80 = 8.0 mm | |

ID./OD. Code : Vinyl Hose

- | | | |
|--------------------------|----------------------------|----------------------------|
| 01 = ID. 2.9, OD. 6.8 mm | 14 = ID. 6.0, OD. 9.0 mm | 37 = ID. 11.0, OD. 15.0 mm |
| 03 = ID. 3.0, OD. 6.0 mm | 17 = ID. 7.0, OD. 9.0 mm | 38 = ID. 12.0, OD. 13.0 mm |
| 05 = ID. 3.5, OD. 6.5 mm | 19 = ID. 7.0, OD. 11.0 mm | 39 = ID. 12.0, OD. 14.0 mm |
| 07 = ID. 4.0, OD. 7.0 mm | 21 = ID. 8.0, OD. 9.0 mm | 40 = ID. 12.0, OD. 16.0 mm |
| 08 = ID. 4.5, OD. 6.5 mm | 23 = ID. 8.0, OD. 12.0 mm | 43 = ID. 13.0, OD. 15.0 mm |
| 09 = ID. 4.5, OD. 8.0 mm | 25 = ID. 9.0, OD. 11.0 mm | 45 = ID. 14.0, OD. 18.0 mm |
| 12 = ID. 5.0, OD. 7.0 mm | 27 = ID. 9.0, OD. 13.0 mm | 50 = ID. 16.0, OD. 19.0 mm |
| 10 = ID. 5.0, OD. 8.0 mm | 33 = ID. 10.0, OD. 14.0 mm | 55 = ID. 17.5, OD. 20.5 mm |
| 11 = ID. 5.0, OD. 9.0 mm | 36 = ID. 11.0, OD. 13.0 mm | 60 = ID. 22.0, OD. 27.0 mm |

Hose Type:

- 1 = Fuel Hose
- 3 = Vinyl Hose
- 5 = Vacuum Hose

CAUTION: Never use vacuum / or vinyl hose in place of fuel hose or vice versa

MASTER INDEX

Title	Grid	Page	Title	Grid	Page
ENGINE SECTION					
CYLINDER	1-C1	1-2			
OIL PAN	1-C1	1-3			
CRANKSHAFT	1-C2	1-5			
PISTON • CONNECTING ROD.....	1-C3	1-6			
CAMSHAFT PULLEY	1-C3	1-7			
RECOIL STARTER	1-C4	1-8			
FAN COVER	1-C4	1-9			
CARBURETOR	1-C5	1-11			
AIR CLEANER	1-C6	1-13			
MUFFLER	1-C7	1-14			
FLYWHEEL (1)	1-C7	1-15			
CHOKE BASE	1-C8	1-16			
LABELS	1-C8	1-17			

ENGINE SECTION
Chapter Table of Contents

Page Title	Grid	Page
CYLINDER	1-C1	1-2
OIL PAN	1-C1	1-3
CRANKSHAFT	1-C2	1-5
PISTON • CONNECTING ROD	1-C3	1-6
CAMSHAFT PULLEY	1-C3	1-7
RECOIL STARTER	1-C4	1-8
FAN COVER	1-C4	1-9
CARBURETOR	1-C5	1-11
AIR CLEANER	1-C6	1-13
MUFFLER	1-C7	1-14
FLYWHEEL (1)	1-C7	1-15
CHOKE BASE	1-C8	1-16
LABELS	1-C8	1-17

CYLINDER

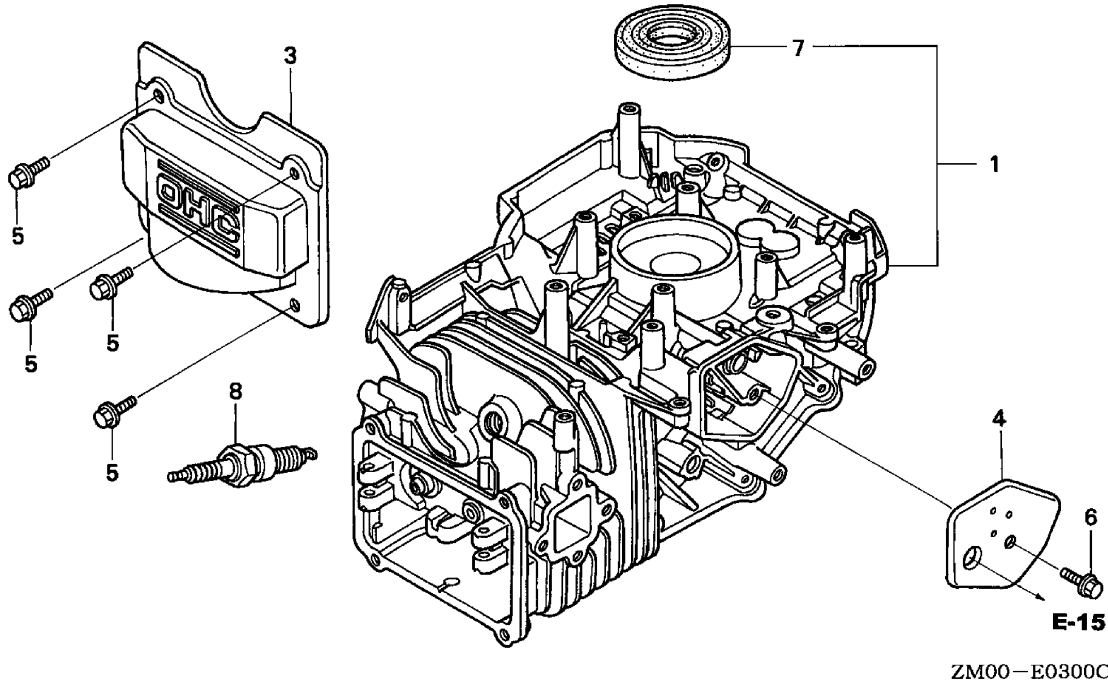

ZM00E0300C

MODEL
A =GCV160A

TYPE
a =S3A

E-3

Ref	Description	Engine Serial Number		QTY	Part Number	H/C
		From	To			
1	CYLINDER ASSY. (010).....	-----	-----	1	12000-ZL8-415	6842413
3	COVER, HEAD.....	-----	-----	1	12311-ZL8-000	5579990
4	COVER, BREATHER (BREATHER VALVE ASSY.).....	-----	-----	1	12355-ZL8-000	5580006
5	BOLT, FLANGE (6X12) (CT200)	-----	-----	4	90013-883-000	0636845
6	BOLT, FLANGE (6X14)	-----	-----	1	90014-952-000	0803619
7	OIL SEAL (25.4X62X6).....	-----	-----	1	91201-ZL8-003	5581038
8	SPARK PLUG (BPR6ES) (NGK)	-----	-----	1	98079-56846	1441112

OIL PAN

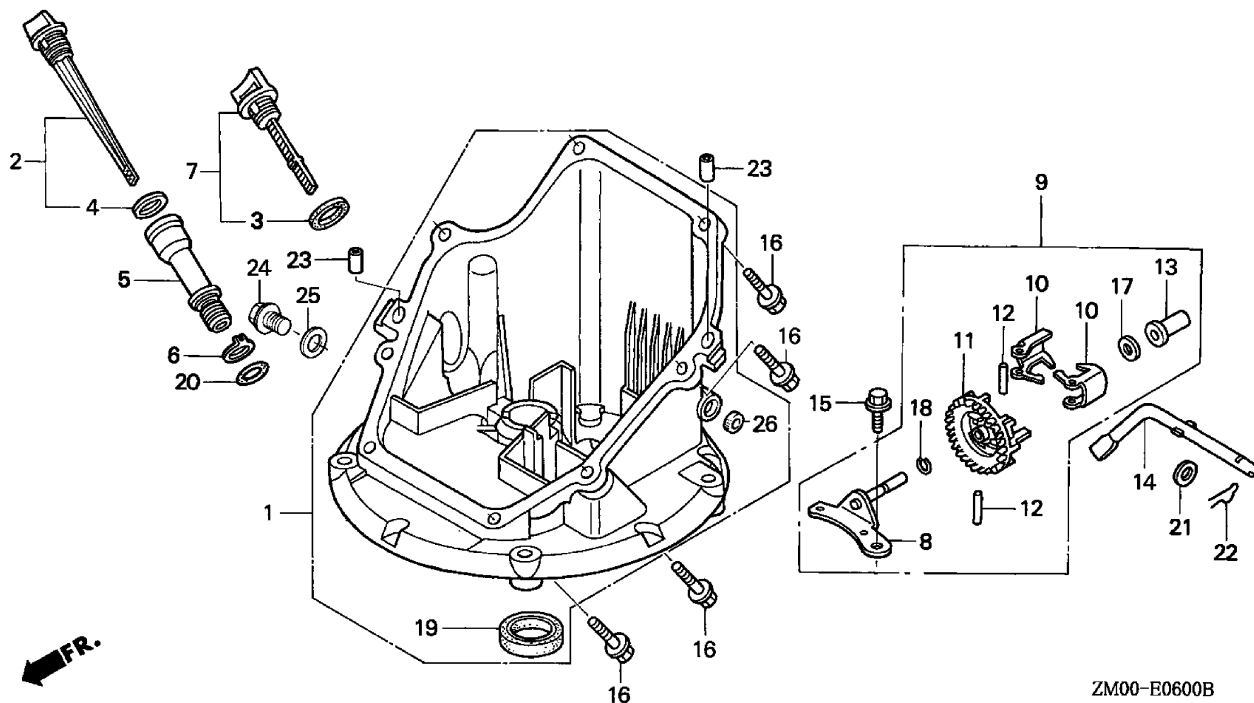

ZM00-B0600B

ZM00E0600B

MODEL **TYPE**
 A =GCV160A a =S3A

E-6

Ref	Description	Engine Serial Number		QTY	Part Number	H/C
		From	To			
20	O-RING (14.8X2.4) (NOK)	-----	-----	1	91356-MA6-005	1377704
21	WASHER, PLAIN (6MM)	-----	-----	1	94101-06800	0345900
22	PIN, LOCK (8MM).....	-----	-----	1	94251-08000	0115527
23	PIN, DOWEL (8X20).....	-----	-----	2	94301-08200	1417369

CRANKSHAFT

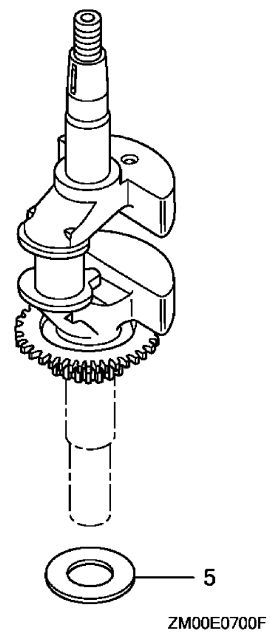
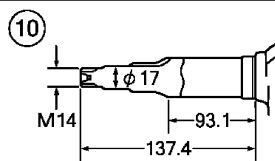
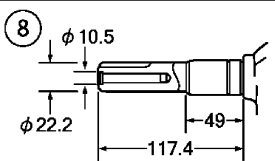
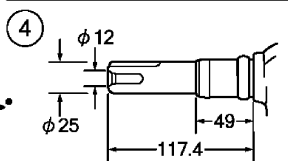
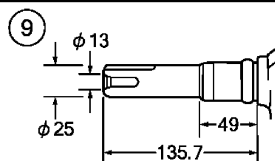
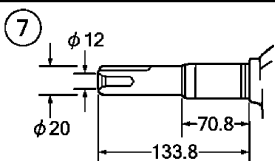
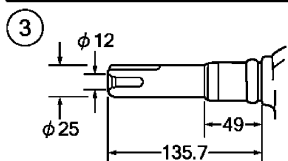
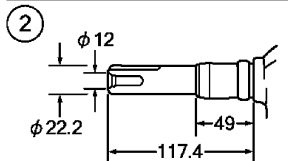
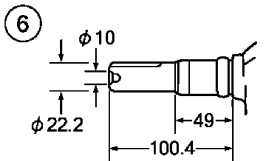
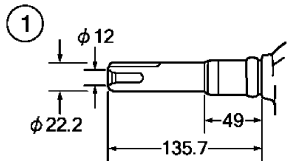

ZM00E0700F

MODEL
A =GCV160A

TYPE
a =S3A

E-7

Ref	Description	Engine Serial Number		QTY	Part Number	H/C
		From	To			
3	CRANKSHAFT (N3-TYPE).....	-----	-----	1	13310-ZM0-610	5664495
5	WASHER, THRUST	-----	-----	1	90402-ZL8-000	5581012

PISTON • CONNECTING ROD

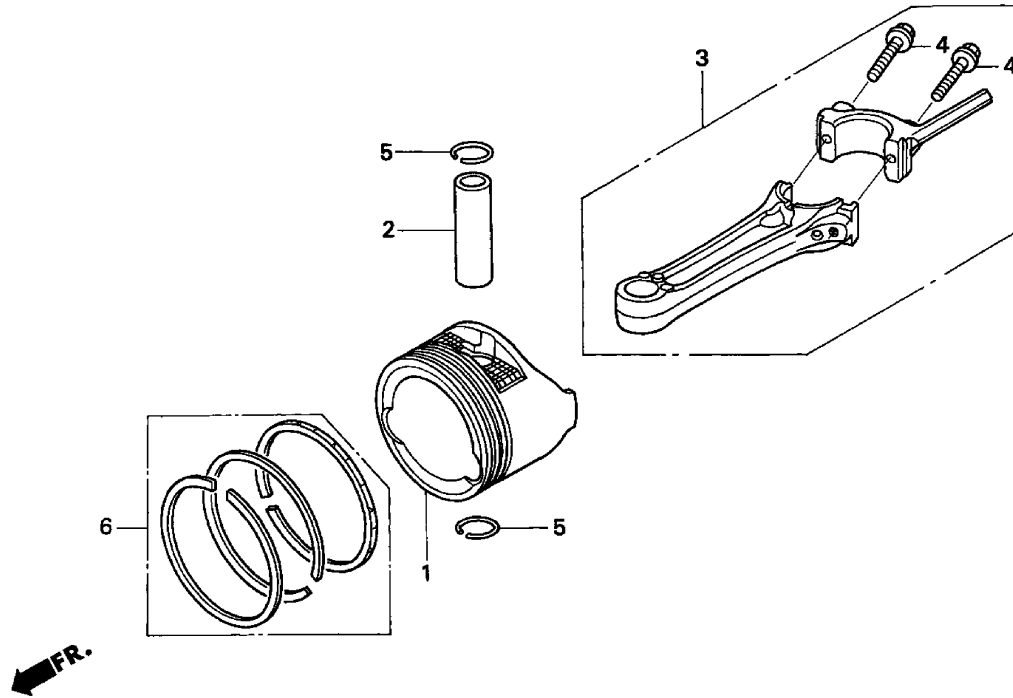

ZM00-E0800A

ZM00E0800A

MODEL **TYPE**
 A =GCV160A a =S3A

E-8

Ref	Description	Engine Serial Number		QTY	Part Number	H/C
		From	To			
1	PISTON	-----	-----	1	13101-Z2A-000	7595705
2	PIN, PISTON	-----	-----	1	13111-ZE0-000	1426576
3	ROD ASSY., CONNECTING	-----	-----	1	13200-ZL8-000	5580022
4	BOLT, CONNECTING ROD	-----	-----	2	90001-ZE1-000	1431055
5	CLIP, PISTON PIN (13MM)	-----	-----	2	90551-ZE0-000	2605517
6	RING SET, PISTON (TEIKOKU)	-----	-----	1	13010-ZL8-024	7154727
	RING SET, PISTON (RIKEN)	-----	-----	1	13010-Z0L-003	8018327

CAMSHAFT PULLEY

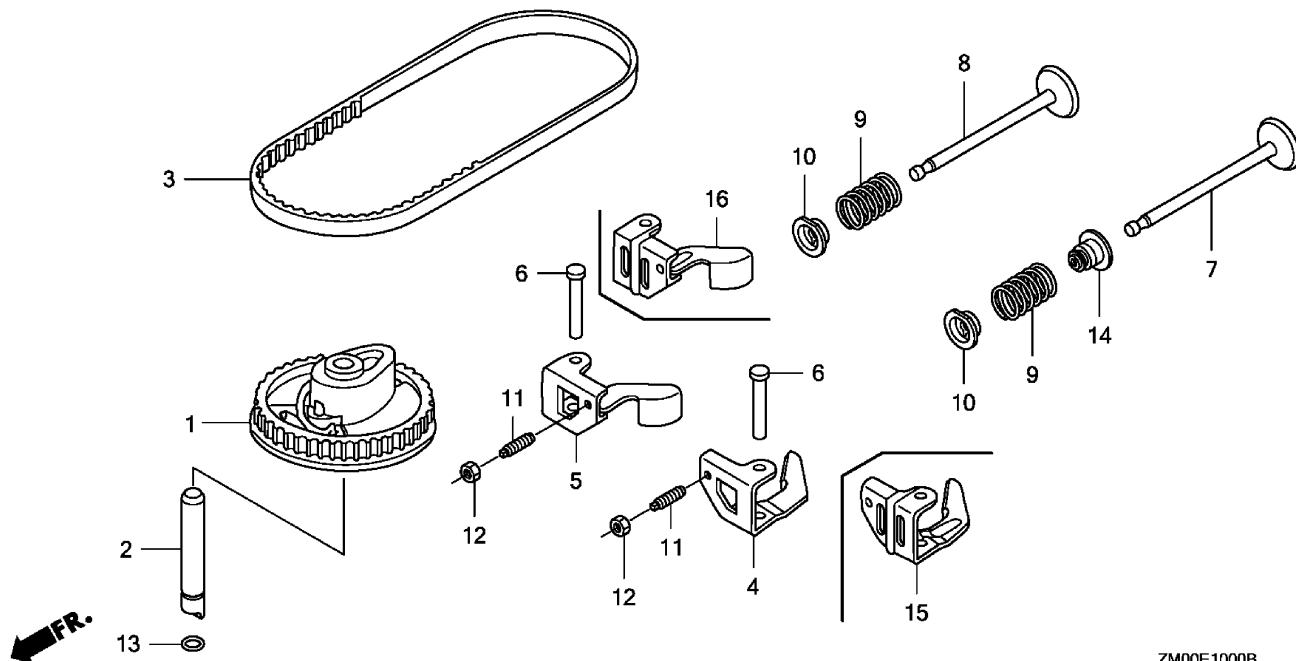

ZM00E1000B

ZM00E1000B

MODEL
A =GCV160A

TYPE
a =S3A

E-10

Ref	Description	Engine Serial Number		QTY	Part Number	H/C
		From	To			
1	PULLEY, CAMSHAFT	-----	-----	1	14320-ZL8-010	7049679
2	SHAFT, CAM PULLEY	-----	-----	1	14324-ZL8-000	5580063
3	BELT, TIMING (84HU7 G-200).....	-----	-----	1	14400-Z0J-014	7058985
6	SHAFT, ROCKER ARM	-----	-----	2	14461-ZL8-000	5580105
7	VALVE, IN.	-----	-----	1	14711-Z0J-000	7647118
8	VALVE, EX.	-----	-----	1	14721-ZL8-000	5580121
9	SPRING, VALVE	-----	-----	2	14751-ZL8-000	5580139
10	RETAINER, IN. VALVE SPRING	-----	-----	2	14771-ZE1-000	1426980
11	SCREW, TAPPET ADJ.	-----	-----	2	90012-333-000	0294819
12	NUT, TAPPET ADJ.	-----	-----	2	90206-001-000	0004598
13	O-RING (6.8X1.9).....	-----	-----	1	91301-ZM0-V31	6315873
14	SEAL, VALVE STEM	-----	-----	1	12209-ZM0-003	6839831
15	ARM, IN. VALVE ROCKER	-----	-----	1	14431-Z0J-000	7526122
16	ARM, EX. VALVE ROCKER.....	-----	-----	1	14441-Z0J-000	7526130

RECOIL STARTER

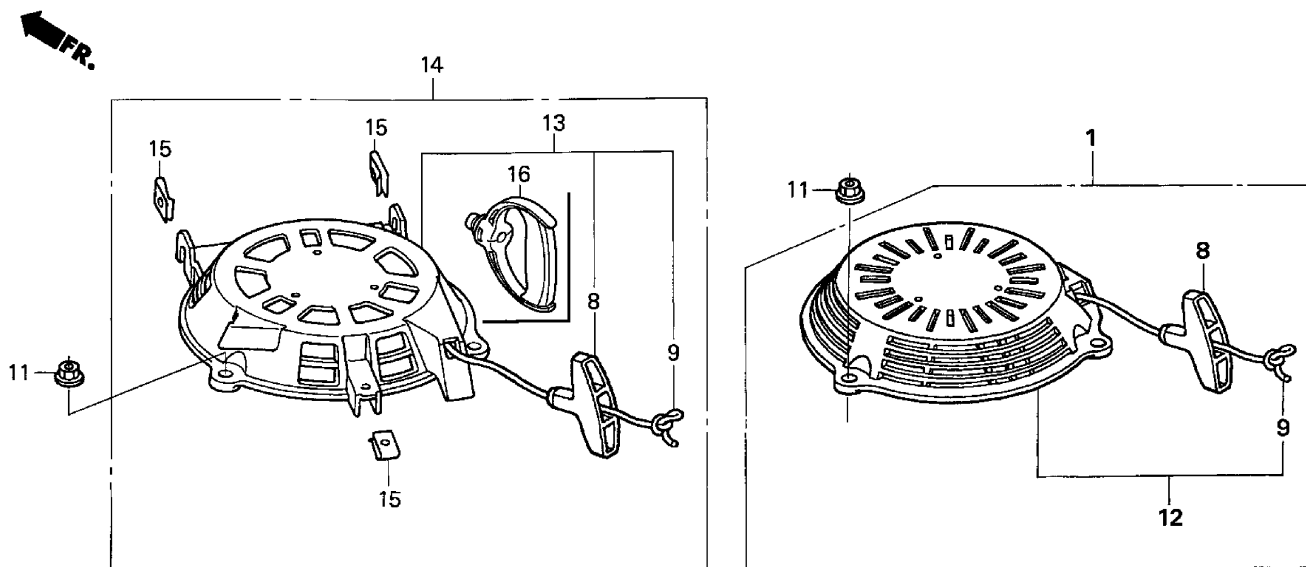

ZM00-E1100E

ZM00E1100E

MODEL
A =GCV160A

TYPE
a =S3A

E-11

Ref	Description	Engine Serial Number		QTY	Part Number	H/C
		From	To			
1	STARTER ASSY., RECOIL *NH1* (LONG ROPE) (BLACK)	-----	3396966	1	28400-ZM0-633ZA	7839210
	STARTER ASSY., RECOIL *NH1* (LONG ROPE) (BLACK)	3396967	-----	1	28400-Z0L-V20ZA	8140147
8	KNOB, RECOIL STARTER	-----	-----	1	28461-ZL8-003	5580634
9	ROPE, RECOIL STARTER (#3.5X90")	-----	3396966	1	28462-ZL8-631	5580642
	ROPE, RECOIL STARTER (LONG TYPE)	3396967	-----	1	28462-Z0L-V20	8106791
11	NUT, FLANGE (6MM).....	-----	-----	3	90201-ZM0-000	6478812

FAN COVER

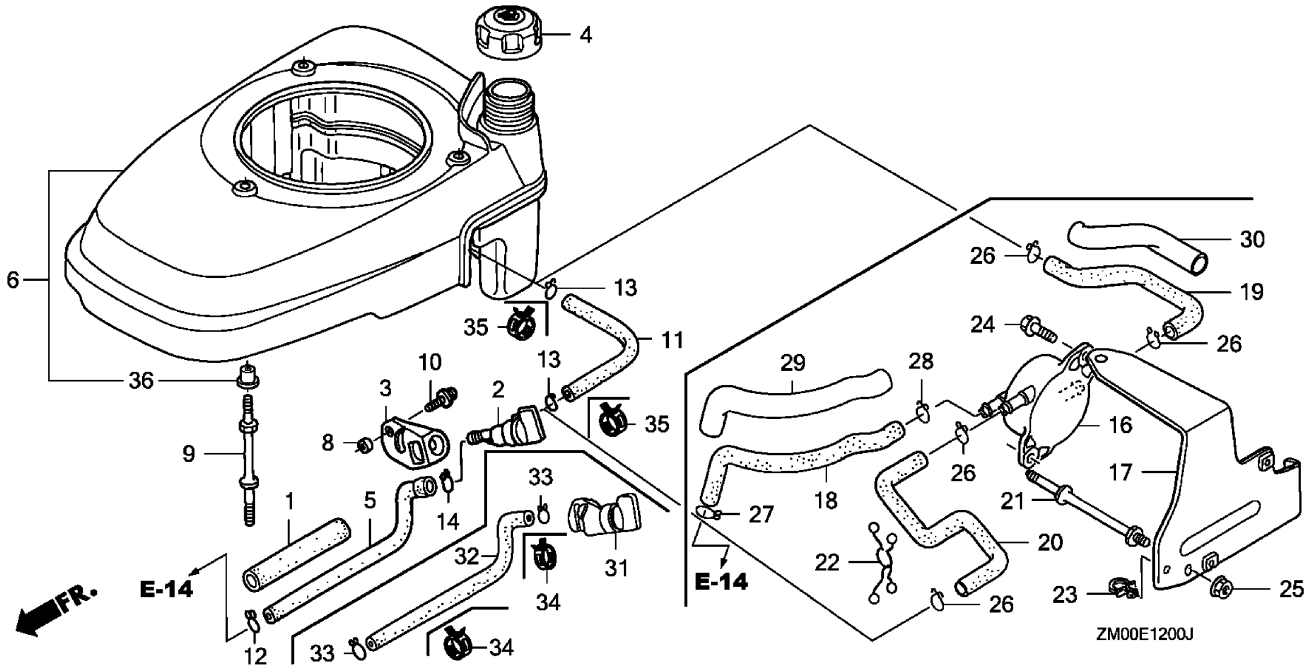

ZM00E1200J

MODEL
A =GCV160A

TYPE
a =S3A

E-12

Ref	Description	Engine Serial Number		QTY	Part Number	H/C
		From	To			
1	RUBBER, SUPPORTER (107MM)	-----	-----	1	16854-ZH8-000	3683646
2	PETCOCK ASSY.....	-----	2510374	1	04103-ZOL-000	8007650
	PETCOCK ASSY.....	-----	2510374	1	16950-ZG9-M03	7357379
3	BRACKET, PETCOCK	-----	2510374	1	16956-ZG9-M00	5189352
4	CAP ASSY., FUEL TANK.....	-----	-----	1	17620-ZL8-013	6673289
5	TUBE, FUEL.....	-----	2510374	1	17702-ZM0-000	5580469
6	COVER, FAN *NH1* (BLACK)	-----	-----	1	19610-ZOL-800ZA	7229875
	COVER, FAN *R280* (POWER RED)	-----	-----	1	19610-ZOL-800ZB	7357411
	COVER, FAN *T89* (CRAFTSMAN RED) ..	-----	-----	1	19610-ZOL-800ZC	7399371
	COVER, FAN *T93* (HUSQVARNA GRAY)	-----	-----	1	19610-ZOL-800ZD	8000549
8	COLLAR, FUEL PETCOCK	-----	-----	1	91501-ZOL-800	6978399
9	BOLT, STUD.....	-----	-----	3	90043-ZL8-000	5581004
10	SCREW-WASHER (5X10)	-----	-----	1	93891-05010-08	0671636
11	TUBE, FUEL TANK	-----	2510374	1	17701-ZOL-000	6754279
	BULK HOSE, FUEL (5.5X3000) (5.5X150)	2510375	-----	1	95001-55003-60M	5338587
12	CLIP, TUBE (B8)	-----	2510374	1	95002-02080	0250647
13	CLIP, TUBE (B10)	-----	-----	2	95002-02100	0250985
14	CLIP, TUBE (C9)	-----	2510374	1	95002-50000	0053447

FAN COVER

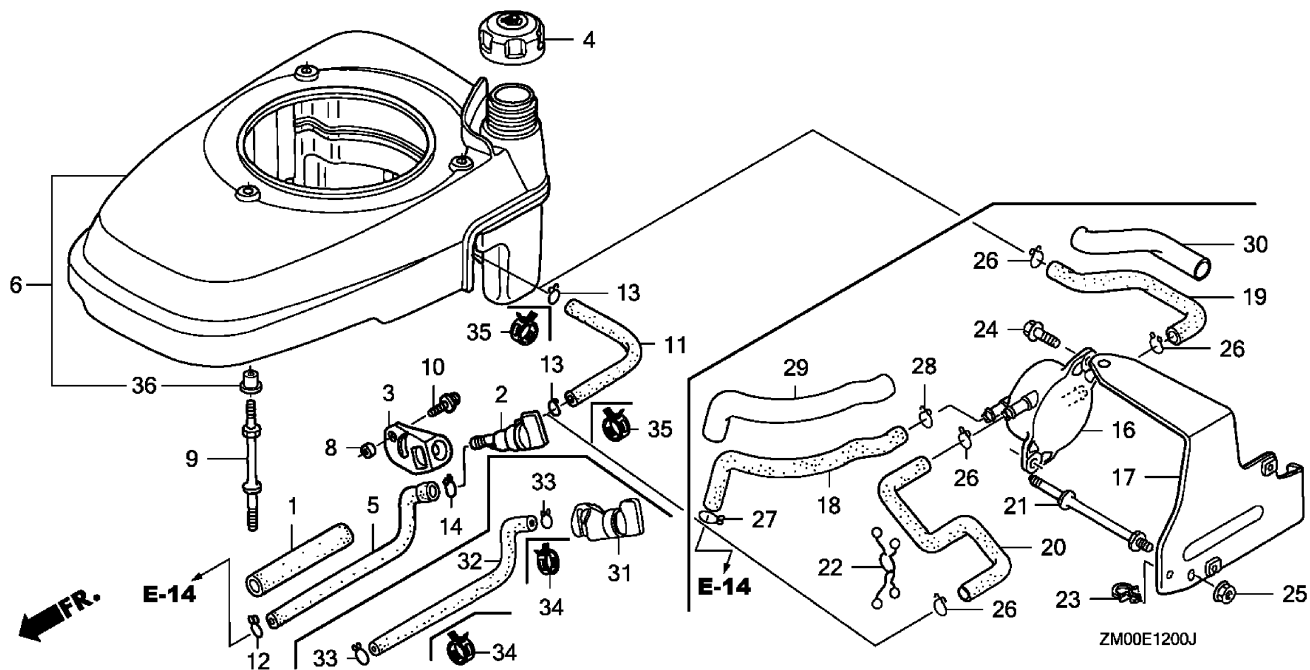

ZM00E1200J

MODEL
A =GCV160A

TYPE
a =S3A

E-12

Ref	Description	Engine Serial Number		QTY	Part Number	H/C
		From	To			
31	PETCOCK ASSY.....	2510375	-----	1	16950-ZM0-003	7425770
32	TUBE, FUEL.....	2510375	-----	1	17702-ZM0-800	7425804
33	CLIP, TUBE (B8)	2510375	-----	2	95002-02080	0250647
36	COLLAR, FAN COVER (N/A: SEE ASSEMBLY)	-----	-----	3	19619-ZL8-300	5580527

CARBURETOR

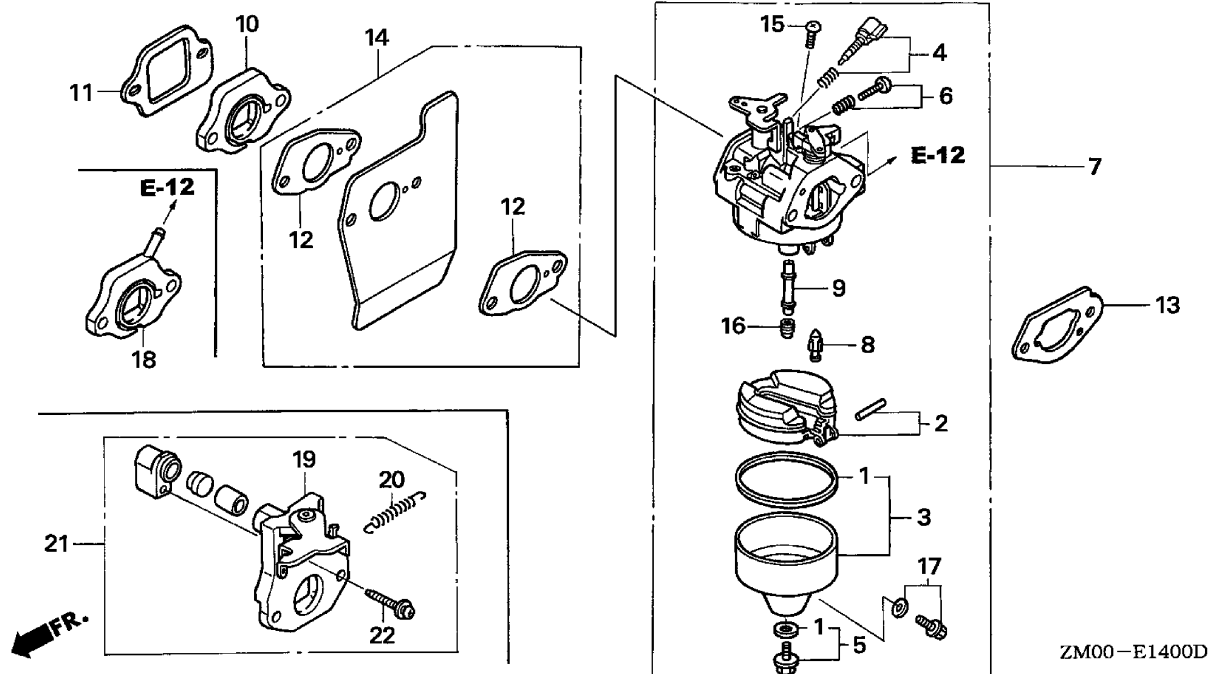

ZM00E1400D

MODEL
A =GCV160A

TYPE
a =S3A

E-14

Ref	Description	Engine Serial Number		QTY	Part Number	H/C
		From	To			
1	GASKET SET	-----	-----	1	16010-883-015	3088416
2	FLOAT SET	-----	-----	1	16013-ZL1-003	5580162
3	CHAMBER SET, FLOAT (CARBURETOR NO.).....	-----	-----	1	16015-887-782	3465879
5	SCREW SET B.....	-----	-----	1	16028-ZE0-005	1441518
7	CARBURETOR ASSY. (BB62G A).....	-----	3172195	1	16100-Z0L-801	7301138
	CARBURETOR ASSY. (BB62G B).....	-----	-----	1	16100-Z0L-802	7866064
8	VALVE, FLOAT (CARBURETOR NO.).....	-----	BB62G A	1	16155-ZM0-003	5580212
	VALVE, FLOAT (CARBURETOR NO.).....	BB62G B	-----	1	16155-ZM0-013	7934714
9	NOZZLE, MAIN.....	-----	-----	1	16166-ZM0-003	5580220
10	INSULATOR, CARBURETOR	-----	-----	1	16211-ZL8-000	5580238
11	GASKET, INSULATOR.....	-----	-----	1	16212-ZL8-000	5580246
12	GASKET, CARBURETOR	-----	-----	2	16221-883-800	4581120
13	GASKET, CARBURETOR (CHOKE SIDE)	-----	-----	1	16228-ZL8-000	5580253
14	GUIDE, AIR	-----	-----	1	19650-ZM0-000	5580535
15	SCREW, PAN (5X6).....	-----	-----	1	93500-05006-0H	0639419

CARBURETOR

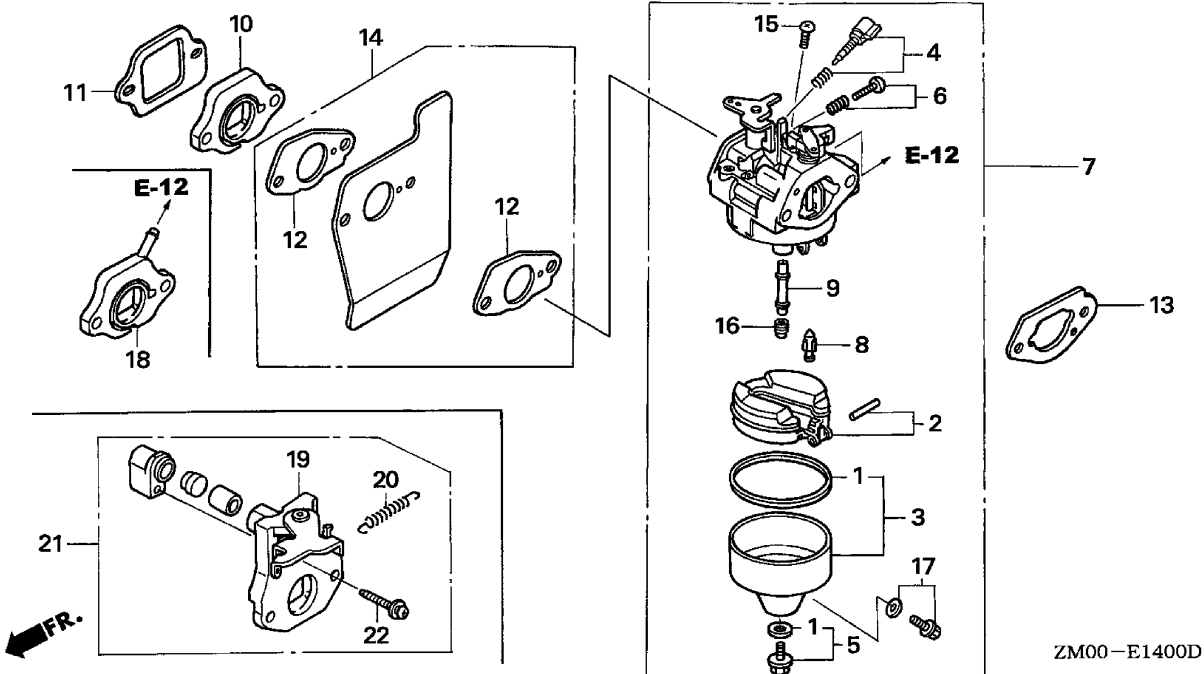

ZM00E1400D

MODEL
A =GCV160A

TYPE
a =S3A

E-14

Ref	Description	Engine Serial Number		QTY	Part Number	H/C
		From	To			
16	JET, MAIN (#60) (CARBURETOR NO.).....	-----	-----	(1)	99101-124-0600	0635474
	JET, MAIN (#62) (CARBURETOR NO.).....	-----	-----	(1)	99101-124-0620	0635482
	JET, MAIN (#65).....	-----	-----	1	99101-124-0650	0636126
17	SCREW SET, DRAIN (CARBURETOR NO.).....	-----	-----	1	16024-ZE1-811	1672187

AIR CLEANER

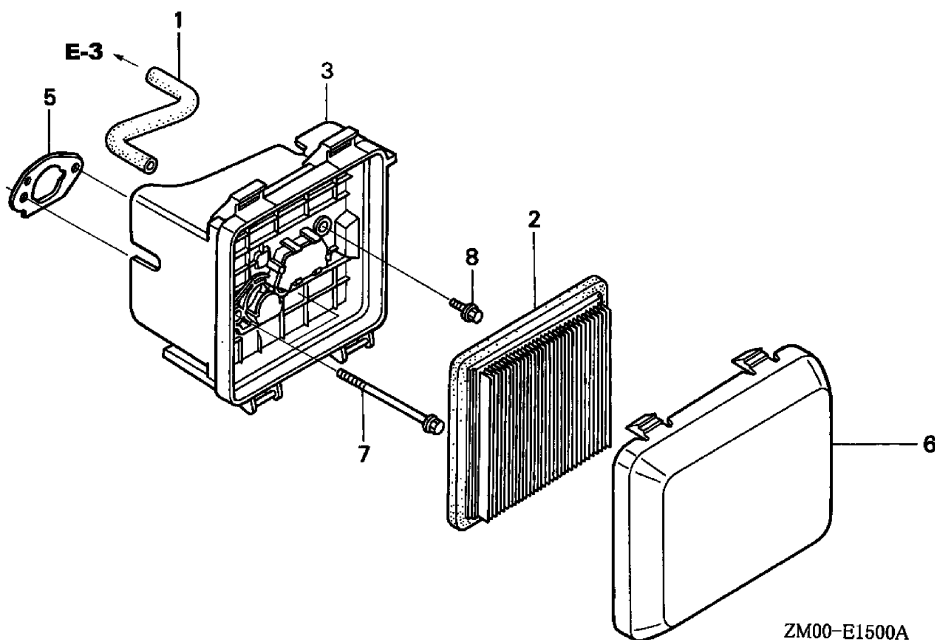

ZM00E1500A

MODEL **TYPE**
 A =GCV160A a =S3A

E-15

Ref	Description	Engine Serial Number		QTY	Part Number	H/C
		From	To			
1	TUBE, BREATHER.....	-----	-----	1	15721-ZM0-000	5580154
2	ELEMENT, AIR CLEANER.....	-----	-----	1	17211-ZL8-023	8236440
3	CASE ASSY., AIR CLEANER	-----	-----	1	17220-ZM0-000	5580410
5	GASKET, AIR CLEANER.....	-----	-----	1	17228-ZM0-000	5664560
6	COVER, AIR CLEANER.....	-----	-----	1	17231-Z0L-030	7745011
7	BOLT, FLANGE (6X86) (CT200)	-----	-----	2	90003-ZM0-000	5580964
8	BOLT, FLANGE (6X14)	-----	-----	1	95701-06014-08	2374742

MUFFLER

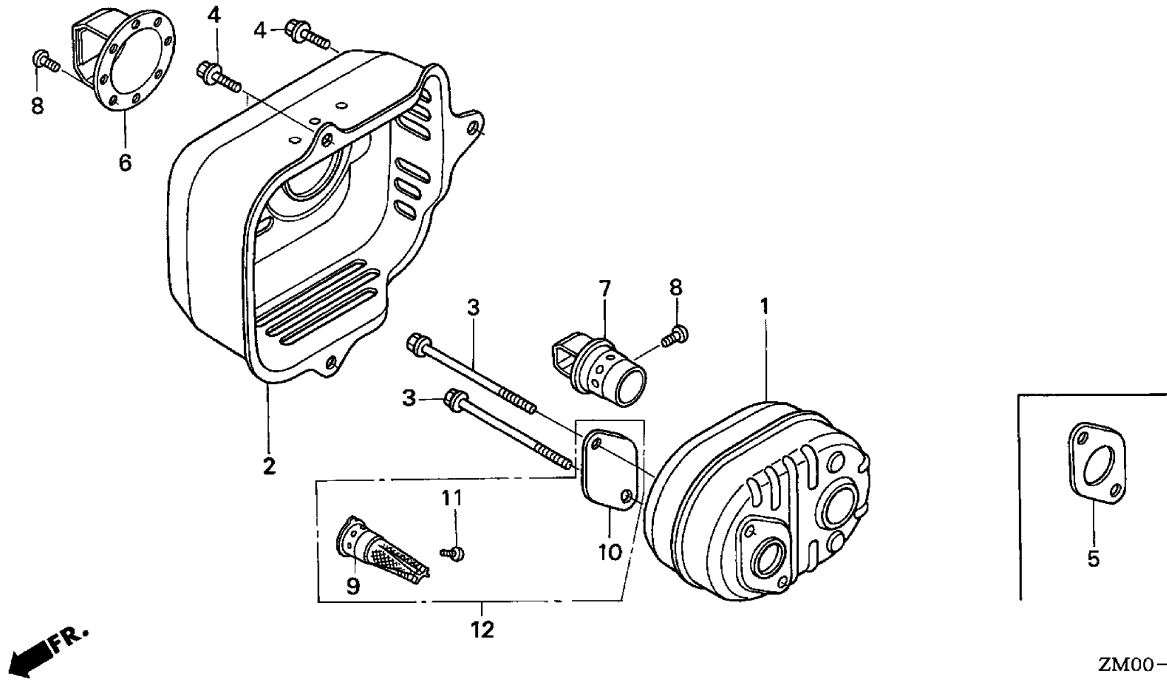

ZM00-E1600F

ZM00E1600F

MODEL **TYPE**
 A =GCV160A a =S3A

E-16

Ref	Description	Engine Serial Number		QTY	Part Number	H/C
		From	To			
1	MUFFLER.....	-----	-----	1	18310-ZM0-000	5580485
2	PROTECTOR, MUFFLER (CBU).....	-----	2307311	1	18321-ZL8-A00	5664610
	PROTECTOR, MUFFLER (CBU).....	2307312	-----	1	18321-Z0L-J00	7377062
3	BOLT, FLANGE (6X79) (CT200).....	-----	-----	2	90004-ZL8-000	5580972
4	BOLT, FLANGE (6X12) (CT200).....	-----	-----	3	90013-883-000	0636845
5	GASKET, MUFFLER.....	-----	-----	(1)	18381-ZL8-305	5737457
9	ARRESTER, SPARK.....	-----	-----	(1)	18350-ZL8-000	5656012
10	PLATE, ARRESTER NUMBER.....	-----	-----	(1)	18356-ZL8-000	5611397
11	SCREW, TAPPING (4X6).....	-----	-----	(1)	90055-ZE1-000	1431121
12	ARRESTER KIT, SPARK.....	-----	-----	(1)	06180-Z0J-000	8213597

FLYWHEEL (1)

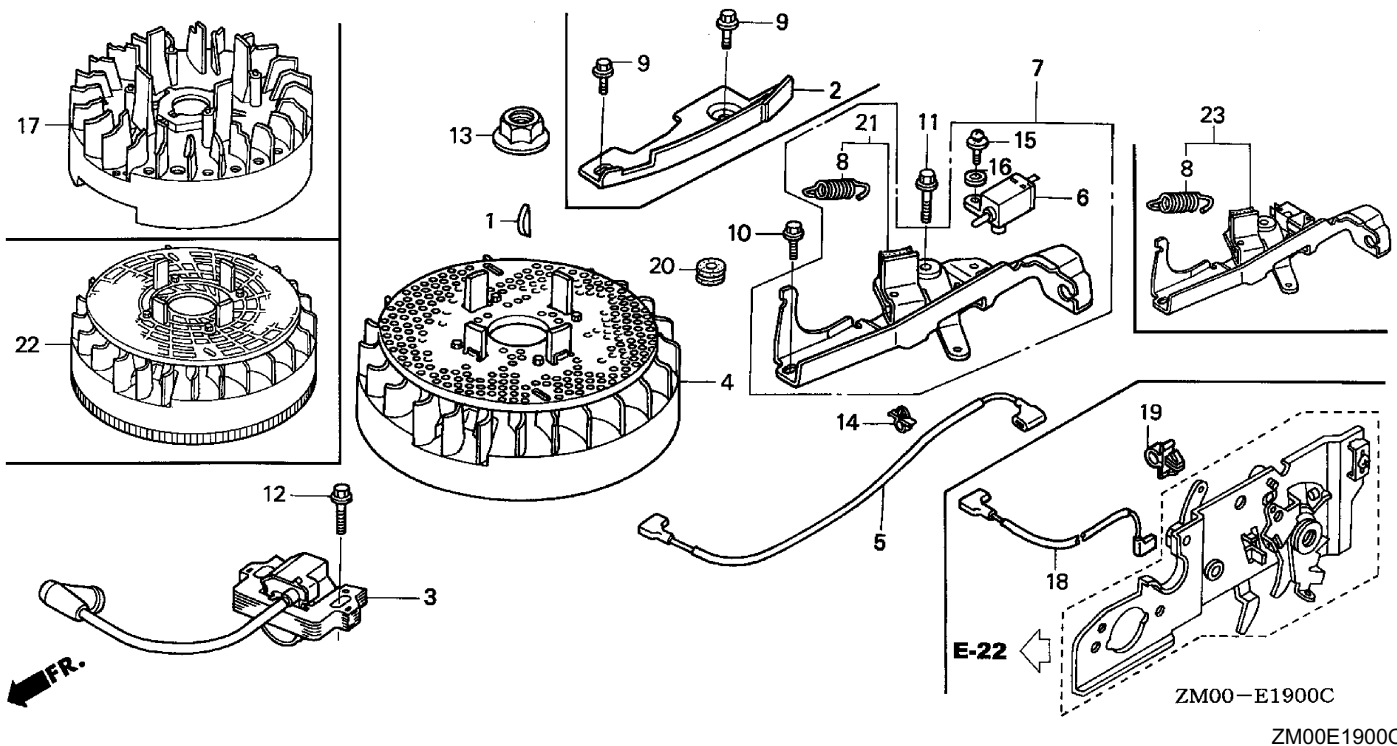

MODEL
A =GCV160A

TYPE
a =S3A

E-19

Ref	Description	Engine Serial Number		QTY	Part Number	H/C
		From	To			
1	KEY, SPECIAL WOODRUFF (25X18)	-----	-----	1	13331-357-000	0348433
3	COIL ASSY., IGNITION	3092798	-----	1	30500-ZL8-004	5580659
	COIL ASSY., IGNITION	-----	3092797	1	30500-Z0J-003	6859722
4	FLYWHEEL ASSY.....	3092798	-----	1	31105-ZM0-000	5580667
	FLYWHEEL ASSY.....	-----	3092797	1	31105-Z0L-010	7489651
5	WIRE, STOP SWITCH	-----	-----	1	32195-ZM0-800	6315816
6	SWITCH ASSY., ENGINE STOP (N.C)	-----	-----	1	35120-ZM0-003	5580683
8	SPRING, BRAKE LEVER.....	-----	-----	1	75113-ZM0-000	5580790
10	BOLT, FLANGE (6X14)	-----	-----	1	90014-952-000	0803619
11	BOLT, FLANGE (6X23)	-----	-----	1	90018-ZE1-000	1725050
12	BOLT, FLANGE (6X20) (CT200)	-----	-----	1	90022-888-010	0671552
13	NUT, SPECIAL (14MM)	-----	-----	1	90201-878-003	0442038
14	CLIP, CABLE (A)	-----	-----	1	90681-959-003	1824630
15	SCREW-WASHER (4X12)	-----	-----	1	93892-04012-00	0485946
16	WASHER, PLAIN (4MM)	-----	-----	1	94103-04000	1510361
20	GROMMET A, RR. COVER	-----	-----	1	11344-MB0-000	1240845
21	BRAKE SUB-ASSY.....	-----	-----	1	75110-Z0L-800	7301591

CHOKE BASE

FR. ←

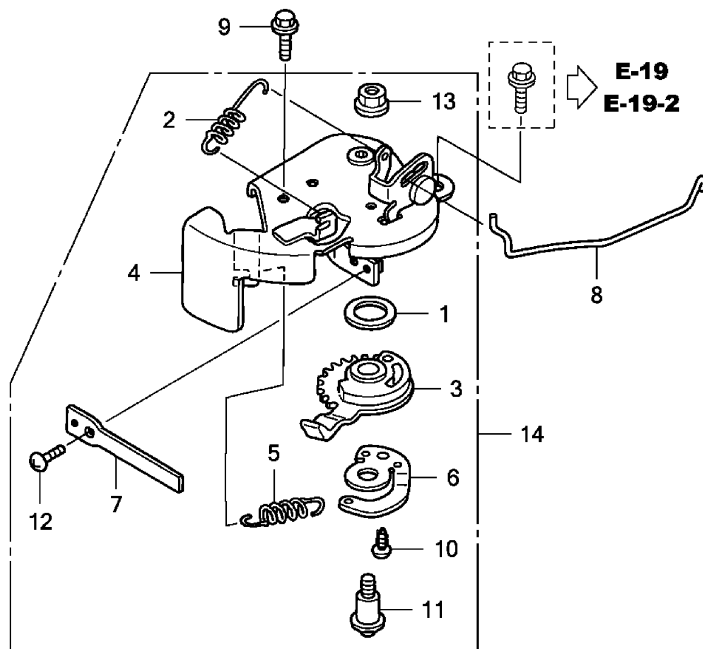

ZM00E2203C

ZM00E2203C

MODEL **TYPE**
 A =GCV160A a =S3A

E-22-3

Ref	Description	Engine Serial Number		QTY	Part Number	H/C
		From	To			
1	SEAL, CHOKE LEVER.....	-----	-----	1	16251-Z0L-800	7257157
2	SPRING, CABLE RETURN	-----	-----	1	16592-ZJ1-000	4209581
3	LEVER, CHOKE	-----	-----	1	16612-Z0L-800	7257165
4	BASE, CHOKE	-----	-----	1	16613-Z0L-800	7257173
5	SPRING, CHOKE LEVER	-----	-----	1	16614-Z0L-800	7257181
6	HOOK, CHOKE SPRING	-----	-----	1	16616-Z0L-800	7257199
7	PLATE, CHOKE	-----	-----	1	16619-Z0L-800	7257207
8	ROD, STOP	-----	-----	1	16632-Z0L-800	7229867
9	BOLT, FLANGE (6X16)	-----	-----	1	90029-888-000	0747733
10	SCREW, TAPPING (4X8) (PO)	-----	-----	1	90102-SP1-003	3674413
11	SCREW, PAN (5X19)	-----	-----	1	90141-KT8-000	2544690
12	SCREW, PAN (4X8)	-----	-----	1	93500-04008-0H	0369017
13	NUT, FLANGE (5MM).....	-----	-----	1	94050-05000	0636951
14	LEVER ASSY., CHOKE	-----	-----	1	16610-Z0L-800	8446270

Part Number Index

PART NUMBER INDEX

Part Number	Grid	Page	Part Number	Grid	Page	Part Number	Grid	Page
(0)			16513-ZE1-000	1-C1	1-3	75113-ZM0-000	1-C7	1-15
04103-ZOL-000	1-C4	1-9	16531-ZE1-000	1-C1	1-3	(8)		
06180-ZOJ-000	1-C7	1-14	16541-ZM0-000	1-C1	1-3	87528-ZOL-V20	1-C8	1-17
(1)			16592-ZJ1-000	1-C8	1-16	(9)		
11300-ZM0-405	1-C1	1-3	16610-ZOL-800	1-C8	1-16	90001-ZE1-000	1-C3	1-6
11300-ZM0-811	1-C1	1-3	16612-ZOL-800	1-C8	1-16	90003-ZM0-000	1-C6	1-13
11344-MB0-000	1-C7	1-15	16613-ZOL-800	1-C8	1-16	90004-ZL8-000	1-C7	1-14
12000-ZL8-415	1-C1	1-2	16614-ZOL-800	1-C8	1-16	90012-333-000	1-C3	1-7
12209-ZM0-003	1-C3	1-7	16616-ZOL-800	1-C8	1-16	90013-883-000	1-C1	1-2
12311-ZL8-000	1-C1	1-2	16619-ZOL-800	1-C8	1-16		1-C7	1-14
12355-ZL8-000	1-C1	1-2	16632-ZOL-800	1-C8	1-16	90014-952-000	1-C1	1-2
13010-ZOL-003	1-C3	1-6	16854-ZH8-000	1-C4	1-9		1-C1	1-3
13010-ZL8-024	1-C3	1-6	16950-ZG9-M03	1-C4	1-9		1-C7	1-15
13101-Z2A-000	1-C3	1-6	16950-ZM0-003	1-C5	1-10	90018-ZE1-000	1-C7	1-15
13111-ZE0-000	1-C3	1-6	16956-ZG9-M00	1-C4	1-9	90022-888-010	1-C7	1-15
13200-ZL8-000	1-C3	1-6	17211-ZL8-023	1-C6	1-13	90029-888-000	1-C8	1-16
13310-ZM0-610	1-C2	1-5	17220-ZM0-000	1-C6	1-13	90043-ZL8-000	1-C4	1-9
13331-357-000	1-C7	1-15	17228-ZM0-000	1-C6	1-13	90055-ZE1-000	1-C7	1-14
14320-ZL8-010	1-C3	1-7	17231-ZOL-030	1-C6	1-13	90102-SP1-003	1-C8	1-16
14324-ZL8-000	1-C3	1-7	17620-ZL8-013	1-C4	1-9	90121-952-000	1-C1	1-3
14400-ZOJ-014	1-C3	1-7	17701-ZOL-000	1-C4	1-9	90141-KT8-000	1-C8	1-16
14431-ZOJ-000	1-C3	1-7	17702-ZM0-000	1-C4	1-9	90201-878-003	1-C7	1-15
14441-ZOJ-000	1-C3	1-7	17702-ZM0-800	1-C5	1-10	90201-ZM0-000	1-C4	1-8
14461-ZL8-000	1-C3	1-7	18310-ZM0-000	1-C7	1-14	90206-001-000	1-C3	1-7
14711-ZOJ-000	1-C3	1-7	18321-ZOL-J00	1-C7	1-14	90402-ZL8-000	1-C2	1-5
14721-ZL8-000	1-C3	1-7	18321-ZL8-A00	1-C7	1-14	90451-ZE1-000	1-C1	1-3
14751-ZL8-000	1-C3	1-7	18350-ZL8-000	1-C7	1-14	90551-ZE0-000	1-C3	1-6
14771-ZE1-000	1-C3	1-7	18356-ZL8-000	1-C7	1-14	90602-ZE1-000	1-C1	1-3
15625-ZE6-000	1-C1	1-3	18381-ZL8-305	1-C7	1-14	90681-959-003	1-C7	1-15
15631-ZM0-000	1-C1	1-3	19610-ZOL-800ZA	1-C4	1-9	91201-ZL8-003	1-C1	1-2
15639-ZM0-000	1-C1	1-3	19610-ZOL-800ZB	1-C4	1-9	91202-ZL8-003	1-C1	1-3
15650-ZM0-801	1-C1	1-3	19610-ZOL-800ZC	1-C4	1-9	91301-ZM0-V31	1-C3	1-7
15721-ZM0-000	1-C6	1-13	19610-ZOL-800ZD	1-C4	1-9	91356-MA6-005	1-C2	1-4
16010-883-015	1-C5	1-11	19619-ZL8-300	1-C5	1-10	91501-ZOL-800	1-C4	1-9
16013-ZL1-003	1-C5	1-11	19650-ZM0-000	1-C5	1-11	93500-04008-0H	1-C8	1-16
16015-887-782	1-C5	1-11	(2)			93500-05006-0H	1-C5	1-11
16024-ZE1-811	1-C6	1-12	28400-ZOL-V20ZA	1-C4	1-8	93891-05010-08	1-C4	1-9
16028-ZE0-005	1-C5	1-11	28400-ZM0-633ZA	1-C4	1-8	93892-04012-00	1-C7	1-15
16100-ZOL-801	1-C5	1-11	28461-ZL8-003	1-C4	1-8	94050-05000	1-C8	1-16
16100-ZOL-802	1-C5	1-11	28462-ZOL-V20	1-C4	1-8	94101-06800	1-C2	1-4
16155-ZM0-003	1-C5	1-11	28462-ZL8-631	1-C4	1-8	94103-04000	1-C7	1-15
16155-ZM0-013	1-C5	1-11	(3)			94251-08000	1-C2	1-4
16166-ZM0-003	1-C5	1-11	30500-ZOJ-003	1-C7	1-15	94301-08200	1-C2	1-4
16211-ZL8-000	1-C5	1-11	30500-ZL8-004	1-C7	1-15	95001-55003-60M	1-C4	1-9
16212-ZL8-000	1-C5	1-11	31105-ZOL-010	1-C7	1-15	95002-02080	1-C4	1-9
16221-883-800	1-C5	1-11	31105-ZM0-000	1-C7	1-15		1-C5	1-10
16228-ZL8-000	1-C5	1-11	32195-ZM0-800	1-C7	1-15	95002-02100	1-C4	1-9
16251-ZOL-800	1-C8	1-16	35120-ZM0-003	1-C7	1-15	95002-50000	1-C4	1-9
16508-ZM0-010	1-C1	1-3	(7)			95701-06014-08	1-C6	1-13
16510-ZM0-010	1-C1	1-3	75110-ZOL-800	1-C7	1-15	98079-56846	1-C1	1-2
16511-ZL8-000	1-C1	1-3				99101-124-0600	1-C6	1-12
16512-ZM0-000	1-C1	1-3				99101-124-0620	1-C6	1-12

PART NUMBER INDEX

Part Number	Grid	Page	Part Number	Grid	Page	Part Number	Grid	Page
-------------	------	------	-------------	------	------	-------------	------	------

99101-124-0650	1-C6	1-12						
----------------------	------	------	--	--	--	--	--	--

Description

Index

DESCRIPTION INDEX

Description	Grid	Page	Ref	Description	Grid	Page	Ref
(A)				CYLINDER ASSY. (010)	1-C1	1-2	1
ARM, EX. VALVE ROCKER	1-C3	1-7	16	(D)			
ARM, IN. VALVE ROCKER	1-C3	1-7	15	DIPSTICK, OIL	1-C1	1-3	2
ARRESTER KIT, SPARK	1-C7	1-14	12	(E)			
ARRESTER, SPARK	1-C7	1-14	9	ELEMENT, AIR CLEANER	1-C6	1-13	2
(B)				EXTENSION, OIL FILLER	1-C1	1-3	5
BASE, CHOKE	1-C8	1-16	4	(F)			
BELT, TIMING (84HU7 G-200)	1-C3	1-7	3	FLOAT SET	1-C5	1-11	2
BOLT, CONNECTING ROD	1-C3	1-6	4	FLYWHEEL ASSY.	1-C7	1-15	4
BOLT, FLANGE (6X12) (CT200)	1-C1	1-2	5	(G)			
	1-C7	1-14	4	GASKET SET	1-C5	1-11	1
BOLT, FLANGE (6X14)	1-C1	1-2	6	GASKET, AIR CLEANER	1-C6	1-13	5
	1-C1	1-3	15	GASKET, CARBURETOR	1-C5	1-11	12
	1-C6	1-13	8	GASKET, CARBURETOR (CHOKE SIDE)	1-C5	1-11	13
	1-C7	1-15	10	GASKET, INSULATOR	1-C5	1-11	11
BOLT, FLANGE (6X16)	1-C8	1-16	9	GASKET, MUFFLER	1-C7	1-14	5
BOLT, FLANGE (6X20) (CT200)	1-C7	1-15	12	GASKET, OIL FILLER CAP	1-C1	1-3	4
BOLT, FLANGE (6X23)	1-C7	1-15	11	GOVERNOR ASSY.	1-C1	1-3	9
BOLT, FLANGE (6X25)	1-C1	1-3	16	GROMMET A, RR. COVER	1-C7	1-15	20
BOLT, FLANGE (6X79) (CT200)	1-C7	1-14	3	GUIDE, AIR	1-C5	1-11	14
BOLT, FLANGE (6X86) (CT200)	1-C6	1-13	7	(H)			
BOLT, STUD	1-C4	1-9	9	HOLDER, GOVERNOR WEIGHT	1-C1	1-3	11
BRACKET, PETCOCK	1-C4	1-9	3	HOOK, CHOKE SPRING	1-C8	1-16	6
BRAKE SUB-ASSY.	1-C7	1-15	21	(I)			
BULK HOSE, FUEL (5.5X3000) (5.5X150)	1-C4	1-9	11	INSULATOR, CARBURETOR	1-C5	1-11	10
(C)				(J)			
CAP ASSY., FUEL TANK	1-C4	1-9	4	JET, MAIN (#60)	1-C6	1-12	16
CARBURETOR ASSY. (BB62G A)	1-C5	1-11	7	JET, MAIN (#62)	1-C6	1-12	16
CARBURETOR ASSY. (BB62G B)	1-C5	1-11	7	JET, MAIN (#65)	1-C6	1-12	16
CASE ASSY., AIR CLEANER	1-C6	1-13	3	(K)			
CHAMBER SET, FLOAT	1-C5	1-11	3	KEY, SPECIAL WOODRUFF (25X18)	1-C7	1-15	1
CLIP, CABLE (A)	1-C7	1-15	14	KNOB, RECOIL STARTER	1-C4	1-8	8
CLIP, GOVERNOR HOLDER	1-C1	1-3	18	(L)			
CLIP, PISTON PIN (13MM)	1-C3	1-6	5	LEVER ASSY., CHOKE	1-C8	1-16	14
CLIP, TUBE (B10)	1-C4	1-9	13	LEVER, CHOKE	1-C8	1-16	3
CLIP, TUBE (B8)	1-C4	1-9	12				
	1-C5	1-10	33				
CLIP, TUBE (C9)	1-C4	1-9	14				
COIL ASSY., IGNITION	1-C7	1-15	3				
COLLAR, FAN COVER	1-C5	1-10	36				
COLLAR, FUEL PETCOCK	1-C4	1-9	8				
COVER, AIR CLEANER	1-C6	1-13	6				
COVER, BREATHER	1-C1	1-2	4				
COVER, FAN *NH1* (BLACK)	1-C4	1-9	6				
COVER, FAN *R280* (POWER RED)	1-C4	1-9	6				
COVER, FAN *T89* (CRAFTSMAN RED)	1-C4	1-9	6				
COVER, FAN *T93* (HUSQVARNA GRAY)	1-C4	1-9	6				
COVER, HEAD	1-C1	1-2	3				
CRANKSHAFT (N3-TYPE)	1-C2	1-5	3				

DESCRIPTION INDEX

Description	Grid	Page	Ref	Description	Grid	Page	Ref
(M)				SCREW, TAPPING (4X8) (PO)	1-C8	1-16	10
MARK, CHOKE INDICATION	1-C8	1-17	9	SCREW-WASHER (4X12)	1-C7	1-15	15
MUFFLER	1-C7	1-14	1	SCREW-WASHER (5X10)	1-C4	1-9	10
(N)				SEAL, CHOKE LEVER	1-C8	1-16	1
NOZZLE, MAIN	1-C5	1-11	9	SEAL, VALVE STEM	1-C3	1-7	14
NUT, FLANGE (5MM)	1-C8	1-16	13	SHAFT, CAM PULLEY	1-C3	1-7	2
NUT, FLANGE (6MM)	1-C4	1-8	11	SHAFT, GOVERNOR ARM	1-C1	1-3	14
NUT, SPECIAL (14MM)	1-C7	1-15	13	SHAFT, GOVERNOR HOLDER	1-C1	1-3	8
NUT, TAPPET ADJ.	1-C3	1-7	12	SHAFT, ROCKER ARM	1-C3	1-7	6
(O)				SLIDER, GOVERNOR	1-C1	1-3	13
O-RING (14.8X2.4) (NOK)	1-C2	1-4	20	SPARK PLUG (BPR6ES) (NGK)	1-C1	1-2	8
O-RING (6.8X1.9)	1-C3	1-7	13	SPRING, BRAKE LEVER	1-C7	1-15	8
OIL SEAL (25.4X62X6)	1-C1	1-2	7	SPRING, CABLE RETURN	1-C8	1-16	2
OIL SEAL (28X41.25X6)	1-C1	1-3	19	SPRING, CHOKE LEVER	1-C8	1-16	5
(P)				SPRING, VALVE	1-C3	1-7	9
PAN ASSY., OIL	1-C1	1-3	1	STARTER ASSY., RECOIL *NH1* (LONG ROPE)			
PAN ASSY., OIL (000)	1-C1	1-3	1	(BLACK)	1-C4	1-8	1
PETCOCK ASSY.	1-C4	1-9	2	SWITCH ASSY., ENGINE STOP (N.C)	1-C7	1-15	6
	1-C5	1-10	31	(T)			
PIN, DOWEL (8X20)	1-C2	1-4	23	TUBE, BREATHER	1-C6	1-13	1
PIN, GOVERNOR WEIGHT	1-C1	1-3	12	TUBE, FUEL	1-C4	1-9	5
PIN, LOCK (8MM)	1-C2	1-4	22		1-C5	1-10	32
PIN, PISTON	1-C3	1-6	2	TUBE, FUEL TANK	1-C4	1-9	11
PISTON	1-C3	1-6	1	(V)			
PLATE, ARRESTER NUMBER	1-C7	1-14	10	VALVE, EX.	1-C3	1-7	8
PLATE, CHOKE	1-C8	1-16	7	VALVE, FLOAT	1-C5	1-11	8
PROTECTOR, MUFFLER (CBU)	1-C7	1-14	2	VALVE, IN.	1-C3	1-7	7
PULLEY, CAMSHAFT	1-C3	1-7	1	(W)			
(R)				WASHER, EXTENSION LOCK	1-C1	1-3	6
RETAINER, IN. VALVE SPRING	1-C3	1-7	10	WASHER, PLAIN (4MM)	1-C7	1-15	16
RING SET, PISTON (RIKEN)	1-C3	1-6	6	WASHER, PLAIN (6MM)	1-C2	1-4	21
RING SET, PISTON (TEIKOKU)	1-C3	1-6	6	WASHER, THRUST	1-C2	1-5	5
ROD ASSY., CONNECTING	1-C3	1-6	3	WASHER, THRUST (6MM)	1-C1	1-3	17
ROD, STOP	1-C8	1-16	8	WEIGHT, GOVERNOR	1-C1	1-3	10
ROPE, RECOIL STARTER (#3.5X90")	1-C4	1-8	9	WIRE, STOP SWITCH	1-C7	1-15	5
ROPE, RECOIL STARTER (LONG TYPE)	1-C4	1-8	9				
RUBBER, SUPPORTER (107MM)	1-C4	1-9	1	(S)			
(S)				SCREW SET B	1-C5	1-11	5
SCREW SET, DRAIN	1-C6	1-12	17	SCREW SET, PAN (4X8)	1-C8	1-16	12
SCREW, PAN (4X8)	1-C8	1-16	12	SCREW, PAN (5X19)	1-C8	1-16	11
SCREW, PAN (5X19)	1-C8	1-16	11	SCREW, PAN (5X6)	1-C5	1-11	15
SCREW, PAN (5X6)	1-C5	1-11	15	SCREW, TAPPET ADJ.	1-C3	1-7	11
SCREW, TAPPET ADJ.	1-C3	1-7	11	SCREW, TAPPING (4X6)	1-C7	1-14	11
SCREW, TAPPING (4X6)	1-C7	1-14	11				