

TRACTOR - MODEL NO. YTH2148 (LO21H48J), PRODUCT NO. 954 57 20-35 SCHEMATIC

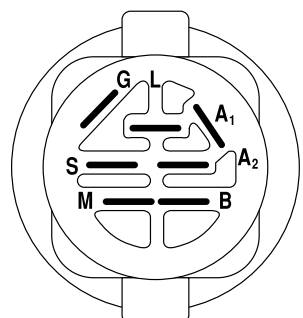
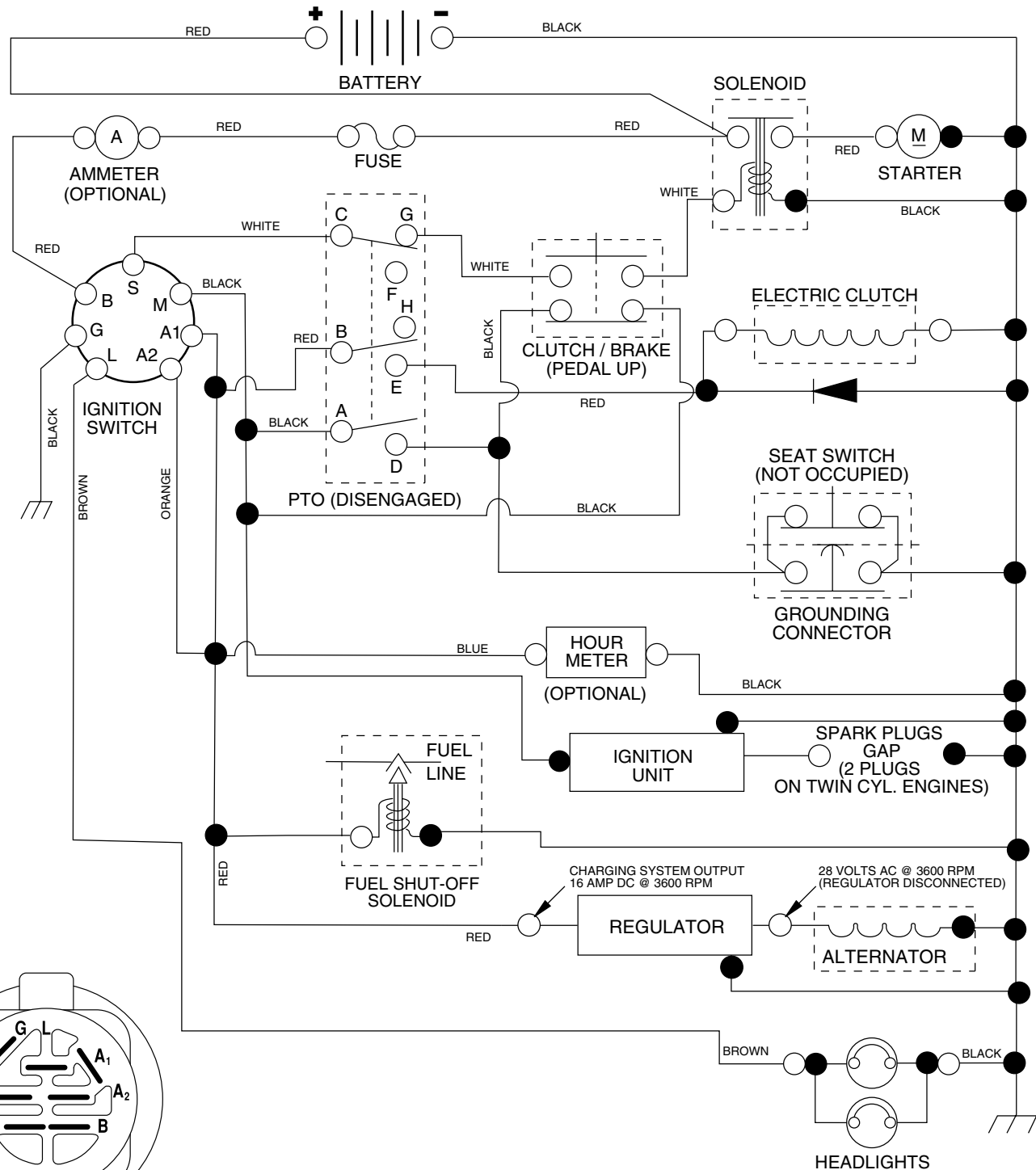

IGNITION SWITCH

POSITION	CIRCUIT	"MAKE"
OFF	M + G + A1	NONE
ON + LIGHTS	B + A1	L + A2
ON	B + A1	NONE
START	B + S + A1	NONE

WIRING INSULATED CLIPS
NOTE: IF WIRING INSULATED CLIPS WERE REMOVED FOR SERVICING OF UNIT, THEY SHOULD BE REPLACED TO PROPERLY SECURE YOUR WIRING.

02757

PTO SWITCH

POSITION	CIRCUIT
OFF	C + G, B + H
ON	C + F, B + E, A + D

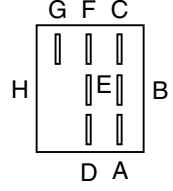

○ REMOVABLE CONNECTIONS

● NON-REMOVABLE CONNECTIONS

PTO SWITCH CONNECTOR

REPAIR PARTS

TRACTOR - MODEL NO. YTH2148 (LO21H48J), PRODUCT NO. 954 57 20-35
ELECTRICAL

KEY NO.	PART NO.	DESCRIPTION
1	532 14 49-27	Battery
2	874 76 04-12	Bolt Hex Hd 1/4-20 unc x 3/4
8	532 18 64-91	Box Battery
16	532 17 61-38	Switch Interlock Push-In
21	532 18 37-59	Harness Asm Light W/4152j
22	532 00 41-52	Bulb Light #1156
24	532 12 47-80	Cable Battery 6 Ga. 11" red
25	532 14 61-48	Cable Battery 6 Ga. 22" red w/16 wire
26	532 17 51-58	Fuse 20 AMP
27	873 51 04-00	Nut Keps Hex 1/4-20 unc
28	532 14 54-91	Cable Ground black
29	532 16 07-84	Switch Plunger Normal Op Olive
30	532 18 96-87	Switch Ign
33	532 14 04-01	Key Ign Molded Generic
40	532 17 97-24	Harness Ign.
41	871 11 04-08	Bolt Blk Fin Hex 1/4 - 20 x 1/2
42	532 13 15-63	Cover Terminal Red
43	532 17 88-61	Solenoid
45	532 12 28-22	Ammeter
46	532 16 96-35	Hourmeter Snap-In
50	532 17 46-51	Switch PTO
81	532 10 97-48	Relay Asm.
89	532 16 96-39	Bracket Snap-In Hourmeter
90	532 18 04-49	Cover Terminal
91	532 19 02-70	Strap Battery

NOTE: All component dimensions given in U.S. inches.
1 inch = 25.4 mm.

REPAIR PARTS

TRACTOR - MODEL NO. YTH2148 (LO21H48J), PRODUCT NO. 954 57 20-35
CHASSIS AND ENCLOSURES

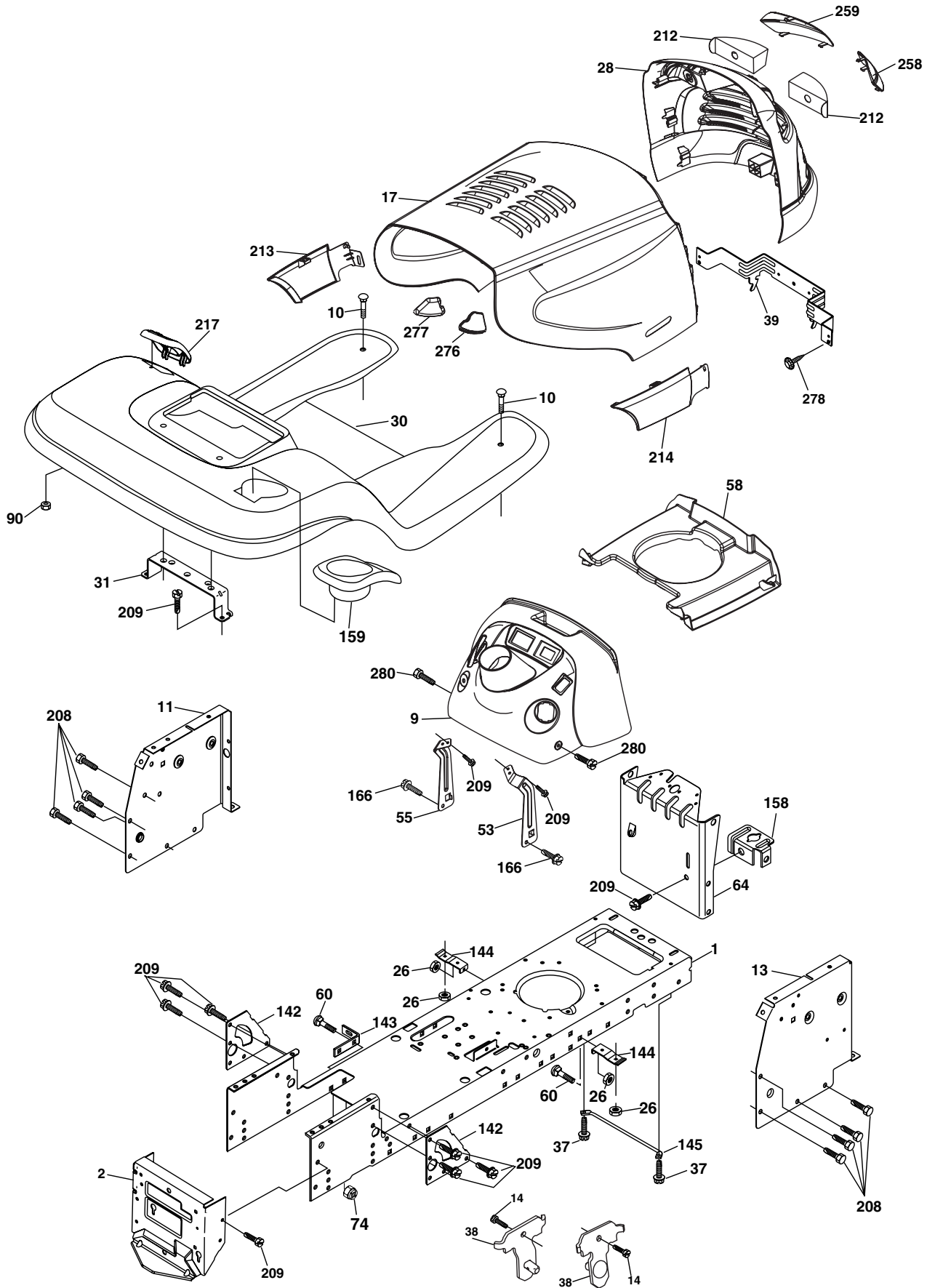

REPAIR PARTS

TRACTOR - MODEL NO. YTH2148 (LO21H48J), PRODUCT NO. 954 57 20-35 CHASSIS AND ENCLOSURES

KEY NO.	PART NO.	DESCRIPTION
1	532 17 46-19	Chassis Stamping
2	532 17 65-54	Drawbar
9	532 19 00-36	Dash P/L M
10	872 14 06-08	Bolt Carriage 3/8-16 x 1
11	532 17 49-96	Panel Dash Lh
13	532 18 17-19	Panel Dash Rh
14	817 49 06-08	Screw Thdrol 3/8-16 x 1/2
17	532 18 99-77	Hood
26	873 80 06-00	Nut Lock Hex W/Ins 3/8-16 unc
28	532 18 82-69	Grille/Lens Asm.
30	532 19 18-15	Fender Footrest STLT Pnt
31	532 13 99-76	Bracket Support Fender
37	817 49 05-08	Screw Thdrol 5/16-18 x 1/2 TYT
38	532 17 57-10	Bracket Asm Pivot Mower Rear
39	532 17 47-14	Bracket Pivot
53	532 18 83-72	Bracket Dash RH
55	532 18 83-73	Bracket Dash LH
58	532 18 93-52	Air Duct Engine
60	872 14 06-06	Bolt Rdhd Sqnk 3/8-16 unc x 3/4
64	532 17 49-97	Dash Lower STLT
74	873 68 06-00	Nut Crownlock 3/8-16 unc
90	532 12 43-46	Nut Self-thd Wsh-Hd 1/4
142	532 17 57-02	Plate Reinforcement STLT
143	532 18 66-89	Bracket Swaybar Chassis
144	532 17 55-82	Bracket Pnt Footrest STLT
145	532 15 65-24	Rod Pivot Chassis/Hood
166	532 17 18-75	Screw HWHD Hi-Lo #13-16 x 3/4
158	532 16 20-37	Bracket Parking Brake
159	532 18 54-34	Cupholder
208	817 67 06-08	Screw Thdrol 3/8-16 x 1/2 TYT BI
209	817 00 06-12	Screw 3/8-16 x 3/4
212	532 18 82-67	Insert Lens Reflect
213	532 18 99-79	Skirt Side LH
214	532 18 99-78	Skirt Side RH
217	532 18 54-36	Console Fuel Window
258	532 18 99-81	Lens RH
259	532 18 99-82	Lens LH
276	532 18 92-74	Bumper Hood RH
277	532 18 92-75	Bumper Hood LH
278	532 19 16-11	Screw 10 x 3/4 Single Lead Hex
280	817 00 06-16	Screw 3/18-16 x 1

NOTE: All component dimensions given in U.S. inches
1 inch = 25.4 mm

REPAIR PARTS

TRACTOR - MODEL NO. YTH2148 (LO21H48J), PRODUCT NO. 954 57 20-35
DRIVE

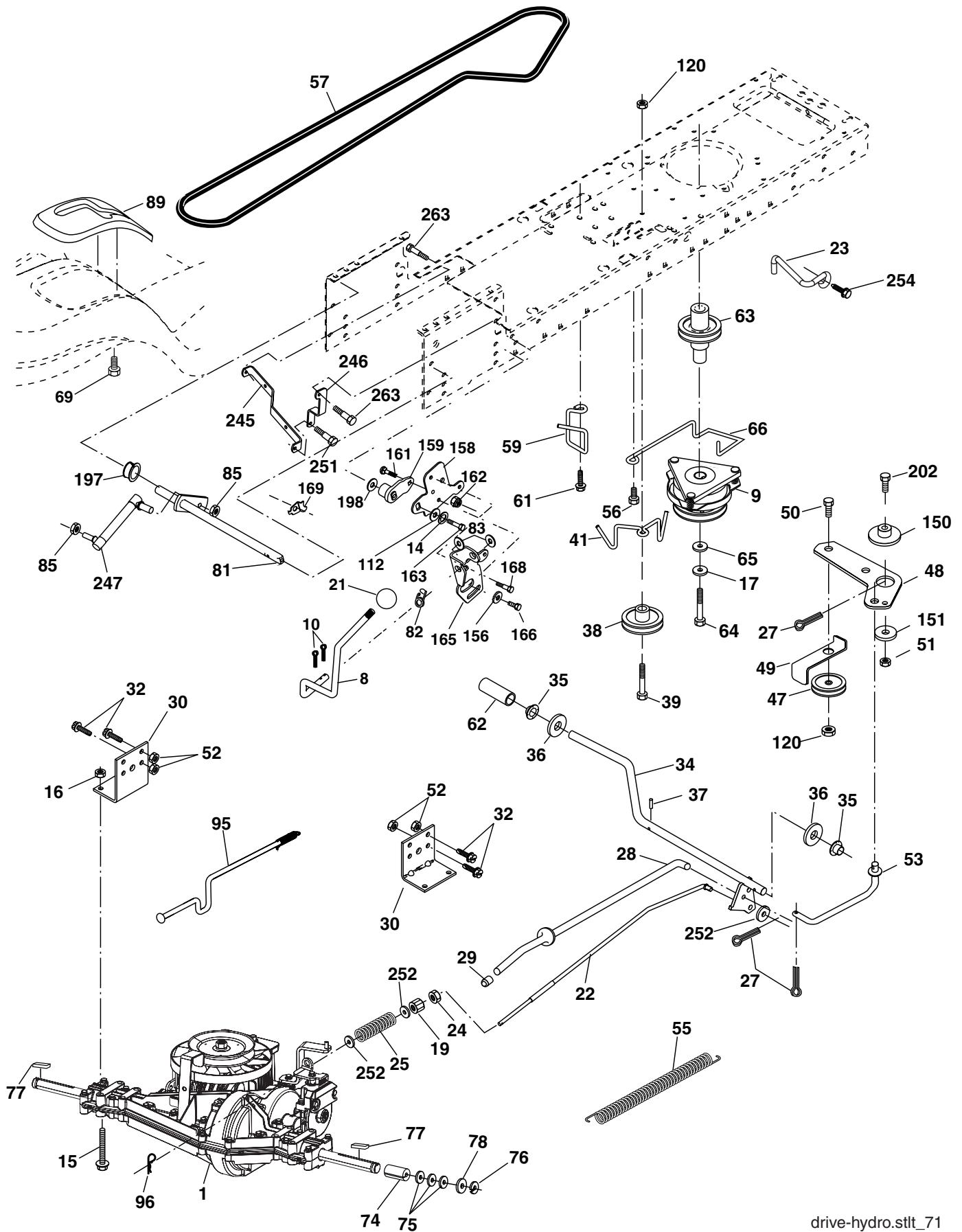

REPAIR PARTS

TRACTOR - MODEL NO. YTH2148 (LO21H48J), PRODUCT NO. 954 57 20-35 DRIVE

KEY NO.	PART NO.	DESCRIPTION	KEY NO.	PART NO.	DESCRIPTION
1	-----	Transaxle Peerless LTH2000 (Order parts from transaxle manufacturer)	64	532 17 39-37	Bolt Hex 7/16-20 x 4 Gr. 5
8	532 16 58-66	Rod Shift Fender Adjust	65	810 04 06-00	Washer
9	532 17 93-34	Clutch Ogura	66	532 15 47-78	Keeper Belt Engine Hydro
10	876 02 04-16	Pin Cotter 1/8 x 1 CAD	69	532 14 24-32	Screw Hex Wsh Hi-Lo 1/4-1/2 unc
14	810 04 04-00	Washer Lock Hvy Helical	74	532 13 70-57	Spacer
15	874 49 05-44	Bolt Hex FLGHD 5/16-18 Gr.5	75	532 12 17-49	Washer 25/32 x 1-1/4 x 16 Ga.
16	873 80 05-00	Nut Lock Hex W/Ins. 5/16-18 unc	76	812 00 00-01	E-Ring
17	532 12 61-97	Washer 1-1/2 OD x 15/32 ID x .250	77	532 12 35-83	Key, Square
19	873 80 06-00	Nut Lock Hex W/Wsh 3/8-16 unc	78	532 12 17-48	Washer 25/32 x 1-5/8 x 16 Ga.
21	532 14 08-45	Knob 1/2-13	81	532 17 81-39	Shaft Asm Cross Tapered
22	532 17 81-41	Rod, Brake	82	532 16 57-11	Spring Torsion
23	532 19 07-36	Bracket Anti-Rotation	83	819 17 12-16	Washer 17/32 x 3/4 x 16 Ga.
24	873 35 06-00	Nut, Hex Jam 3/8-16 unc	85	532 15 03-60	Nut Lock Center 1/4-28 FNTHD
25	532 10 68-88	Spring, Brake Rod	89	532 19 18-16	Console, Shift
27	876 02 04-12	Pin Cotter 1/8 x 3/4 CAD.	95	532 17 81-34	Disconnect Asm Rod Bypas LTH
28	532 17 57-65	Rod, Parking Brake	96	532 12 47-88	Retainer Spring 1" Zinc/Cad
29	532 07 16-73	Cap, Parking Brake	112	819 09 12-10	Washer 9/32 x 3/4 x 10 Ga.
30	532 16 95-92	Bracket, Transaxle	120	873 90 06-00	Nut Lock Flg 3/8-16
32	874 76 05-12	Bolt Hex Hd 5/16-18 unc x 3/4	150	532 17 54-56	Spacer Retainer
34	532 17 55-78	Shaft, Foot Pedal	151	819 13 32-10	Washer 13/32 x 2 x 10 Ga.
35	532 12 01-83	Bearing, Nylon	156	532 16 60-02	Washer Srrted 5/16 ID x 1.125
36	819 21 16-16	Washer	158	532 16 55-89	Bracket Shift Mount
37	532 12 49-63	Pin, Roll	159	532 18 39-00	Hub Shift
38	532 17 91-14	Pulley, Composite	161	872 14 04-06	Bolt Rdhd Sqnk 1/4-20 x 3/4 Gr 5
39	872 11 06-22	Bolt RDHD 3/8-16 unc x 2 3/4 Gr. 5	162	873 68 04-00	Nut Crownlock 1/4-20 unc
41	532 17 55-56	Keeper, Belt Idler	163	874 78 04-16	Bolt Hex Fin 1/4-20 unc x 1 Gr 5
47	532 12 77-83	Pulley, Idler, V-Groove	165	532 16 56-23	Bracket Pivot Lever
48	532 15 44-07	Bellcrank, Clutch	166	817 49 05-10	Screw 5/16-18 x 5/8
49	532 12 32-05	Retainer, Belt	168	532 16 54-92	Bolt Shoulder 5/16-18 x .561
50	872 11 06-12	Bolt Carr Sh 3/8-16 x 1-1/2 Gr 5	169	532 16 55-80	Plate Fastening
51	873 68 06-00	Nut Crownlock 3/8-16 unc	197	532 16 96-13	Nyliner Snap-In 5/8"ID
52	873 68 05-00	Nut, Crownlock 5/16-18 unc	198	532 16 95-93	Washer Nyl 7/8 ID x .105" Hyd
53	532 10 57-10	Link, Clutch	202	872 11 06-14	Bolt Carr Sh 3/8-16 x 1-3/4 Gr.5
55	532 10 57-09	Spring, Return, Clutch	245	532 17 81-22	Strap Torque Lh LTH2000
56	817 06 06-20	Screw 3/8-16 x 1-1/4	246	532 17 81-21	Strap Torque Rh LTH2000
57	532 17 81-38	V-Belt	247	532 18 14-62	Link Shift Transaxle LTH2000
59	532 16 96-91	Keeper, Center Span	251	817 06 05-16	Screw 5/16-18 x 1
61	817 12 06-14	Screw 3/8-16 x .875	252	819 13 16-16	Washer 13/32 x 1 x 16 Ga.
62	532 12 48-72	Cover, Pedal	254	817 00 06-16	Screw 3/8-16 x 1
63	532 17 46-07	Pulley, Engine	263	817 00 06-12	Screw Hex Wsh Thdr 3/8-16 x 3/4

NOTE:All component dimensions give in U.S. inches.
1 inch = 25.4 mm.

REPAIR PARTS

TRACTOR - MODEL NO. YTH2148 (LO21H48J), PRODUCT NO. 954 57 20-35
STEERING ASSEMBLY

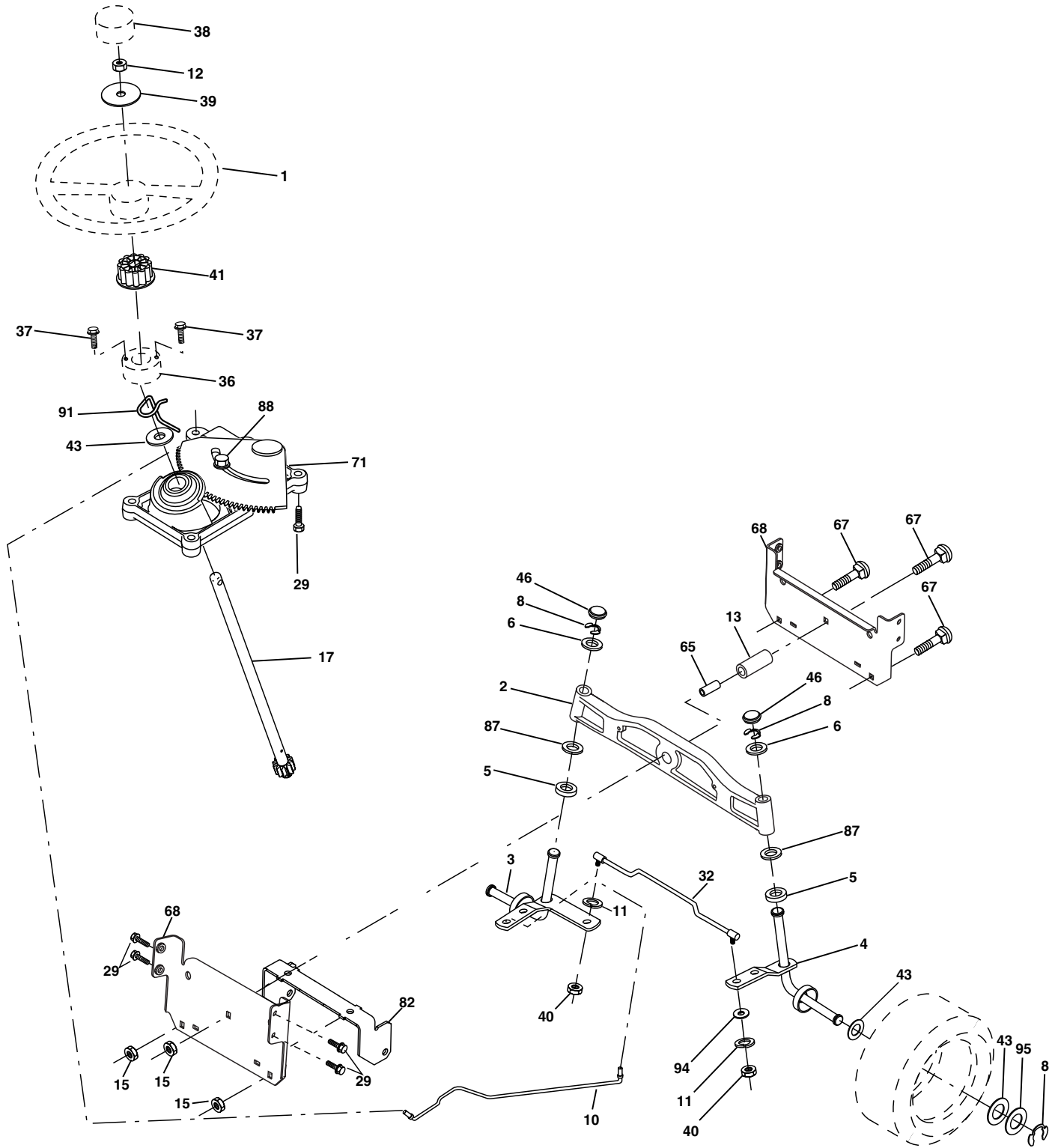

steering_pl.lt_54

REPAIR PARTS

TRACTOR - MODEL NO. YTH2148 (LO21H48J), PRODUCT NO. 954 57 20-35 STEERING ASSEMBLY

KEY NO.	PART NO.	DESCRIPTION
1	532 16 66-27	Wheel Steering
2	532 18 47-06	Axle
3	532 16 98-40	Spindle Asm LH
4	532 16 98-39	Spindle Asm RH
5	532 12 49-31	Bearing Race Thrust Harden
6	532 12 17-48	Washer 25/32 x 1-5/8 x 16 Ga.
8	812 00 00-29	Ring Klip #t5304-75
10	532 17 51-21	Link Drag
11	810 04 06-00	Washer Lock Hvy Hlcl Spr 3/8
12	873 94 08-00	Nut Hex Jam Toplock 1/2-20 unf
13	532 13 65-18	Spacer Brg Axle Front
15	532 14 52-12	Nut Hex Flange Lock
17	532 17 78-83	Shaft Asm Strg
29	817 00 06-12	Screw 3/8-16 x 3/4
32	532 18 05-80	Rod Tie
34	810 04 05-00	Washer Lock Hvy Helical 5/16
36	532 15 51-05	Bushing Strg
37	532 15 29-27	Screw
38	532 16 66-26	Insert Cap Strg Wh
39	819 18 38-12	Washer 9/16 x 2-3/8 12 Ga.
40	873 54 06-00	Nut Crownlock 3/8-24
41	532 15 99-45	Adaptor Wheel Strg
43	532 12 17-49	Washer 25/32 x 1 1/4 x 16 Ga.
46	532 12 12-32	Cap Spindle Fr Top Blk
65	532 16 03-67	Spacer Brace Axle
67	872 11 06-18	Bolt Rdhd Sq 3/8-16 x 2-1/4
68	532 16 98-27	Axle, Brace
71	532 17 51-46	Steering Asm
82	532 16 98-35	Bracket Susp Chassis Front
87	532 17 39-66	Washer Flat .781 x 1-1/2 x .14
88	532 17 51-18	Bolt Shoulder 7/16-20
91	532 17 55-53	Clip Steering
94	819 12 14-14	Washer 3/8 x 7/8 x 14 Ga.
95	532 18 89-67	Washer Hardened

NOTE: All component dimensions given in U.S. inches.
1 inch = 25.4 mm.

REPAIR PARTS

TRACTOR - MODEL NO. YTH2148 (LO21H48J), PRODUCT NO. 954 57 20-35
SEAT ASSEMBLY

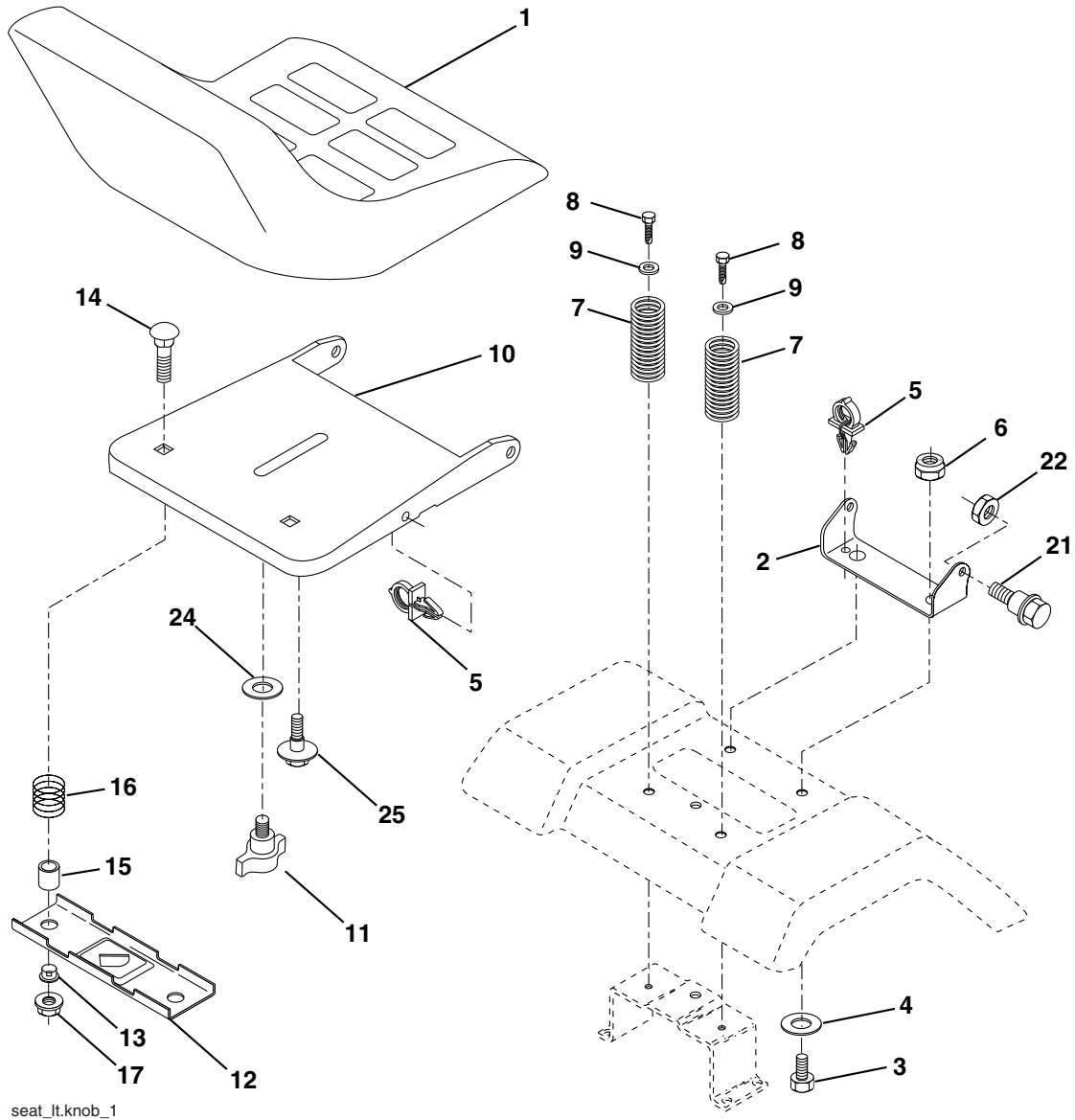

seat_lt.knob_1

KEY NO.	PART NO.	DESCRIPTION
1	532 18 87-15	Seat
2	532 14 05-51	Bracket Pivot Seat 8 720
3	871 11 06-16	Bolt Fin Hex 3/8-16 unc x 1
4	819 13 16-10	Washer 13/32 x 1 x 10 Ga.
5	532 14 50-06	Clip Push-In
6	873 80 06-00	Nut Hex w/Ins. 3/8-16 unc
7	532 12 41-81	Spring Seat Cprsn 2 250 Blk Zi
8	817 00 06-16	Screw 3/8-16 x 1-1/2 Smgml Tap/R Z
9	819 13 16-14	Washer 13/32 x 1 x 14 Ga.
10	532 18 24-93	Pan Seat
11	532 16 63-69	Knob Seat Adj. Wingnut
12	532 12 12-46	Bracket Mounting Switch
13	532 12 12-48	Bushing Snap Blk Nyl 50 Id

KEY NO.	PART NO.	DESCRIPTION
14	872 05 04-12	Bolt Rdhd Sqnk 1/4-2 x 1-1/2
15	532 12 17-49	Spacer
16	532 12 37-40	Spring Cprsn
17	532 12 39-76	Nut Lock 1/4 Lge Flg Gr. 5 Zinc
21	532 17 18-52	Bolt Shoulder 5/16-18 unc-2a Blk DA
22	873 80 05-00	Nut Hex Lock W/Ins 5/16-18
24	819 17 19-12	Washer 17/32 x 13/16 x 12 Ga.
25	532 12 70-18	Bolt Shoulder 5/16-18 x 62

NOTE: All component dimensions given in U.S. inches.
1 inch = 25.4 mm

REPAIR PARTS

TRACTOR - MODEL NO. YTH2148 (LO21H48J), PRODUCT NO. 954 57 20-35
DECALS

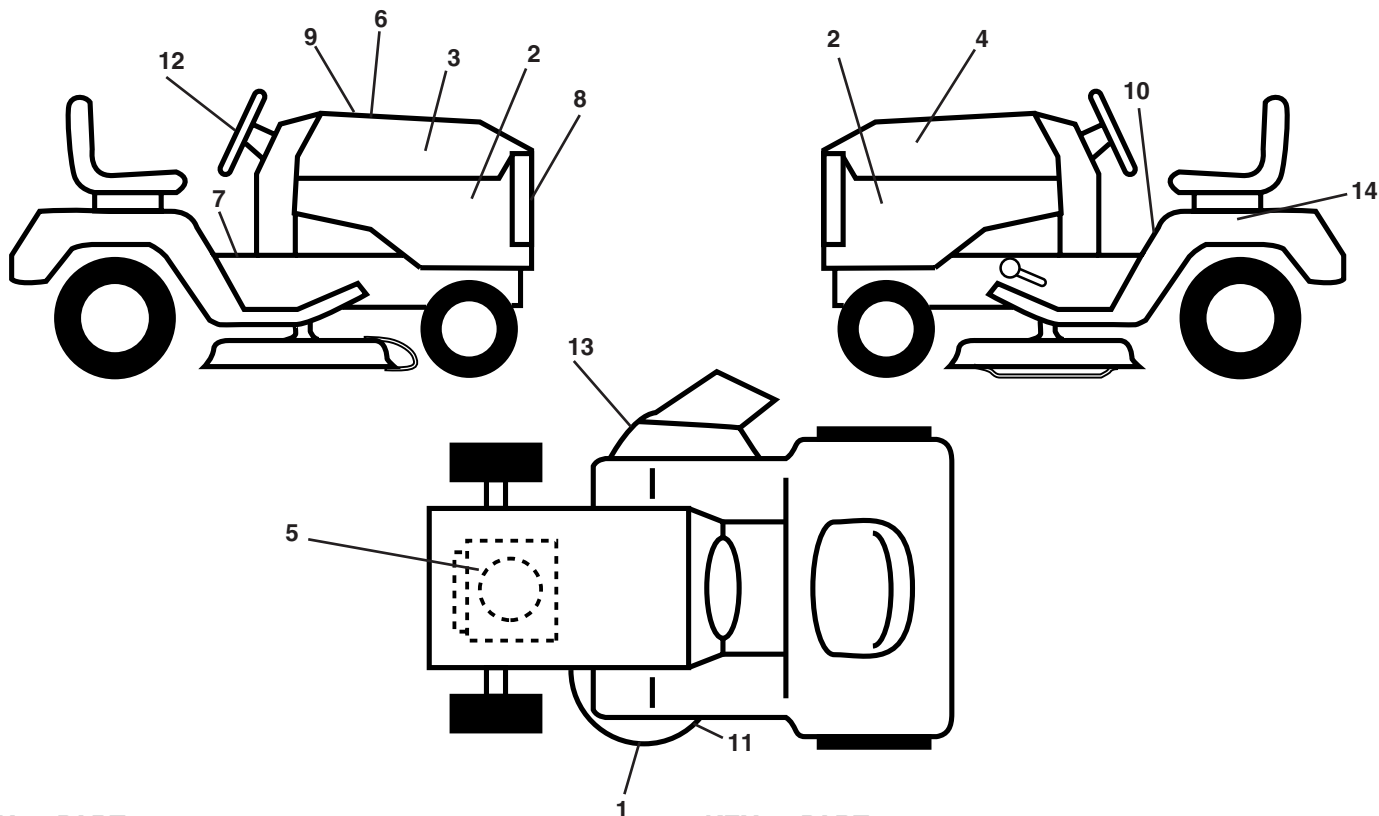

KEY NO.	PART NO.	DESCRIPTION
1	532 17 84-82	Decal Deck Hvy Duty
2	532 19 22-01	Decal Panel Side
3	532 18 89-18	Decal Hood RH
4	532 18 89-19	Decal Hood LH
6	532 18 09-41	Decal Hood Cust. Resp.
7	532 15 70-32	Decal Operator
8	532 18 92-43	Decal Dash
9	532 19 23-23	Decal Replacement
10	532 15 71-40	Decal Fender Danger
11	532 17 52-91	Decal V-Belt Sch.

KEY NO.	PART NO.	DESCRIPTION
12	532 18 89-25	Decal Wheel Steering
13	532 17 05-63	Decal Warning
14	532 14 50-05	Decal Bat Dan/Psn
--	532 17 83-92	Decal Chass. Disconnect
--	532 18 82-52	Pad Footrest LH STLT
--	532 18 82-53	Pad Footrest RH STLT
--	532 13 83-11	Decal Handle Lft Height Adjust
--	532 19 28-62	Manual Operator's (English)

WHEELS & TIRES

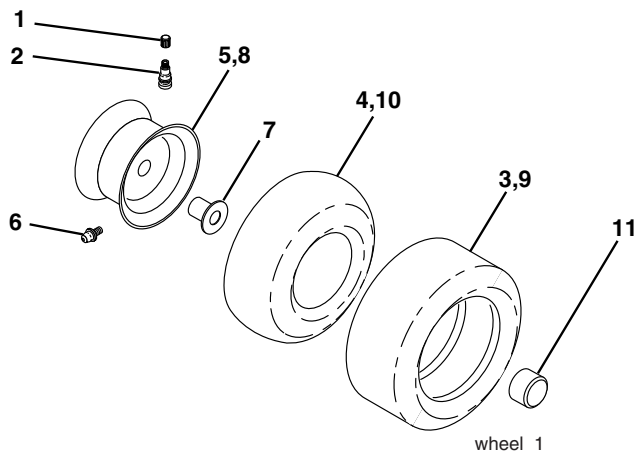

KEY NO.	PART NO.	DESCRIPTION
1	532 05 91-92	Cap Valve Tire
2	532 06 51-39	Stem Valve
3	532 10 62-22	Tire F Ts 15 x 6 0 - 6 Service
4	532 05 99-04	Tube Front (Service Item Only)
5	532 13 83-36	Rim Asm 6"front Silver Service
6	532 12 49-57	Fitting Grease (Front Wheel Only)
7	532 12 49-59	Bearing Flange (Front Wheel Only)
8	532 13 83-37	Rim Asm 8"rear Silver Service
9	532 12 20-82	Tire R Ts 20 x 10-8 C Service
10	532 12 49-26	Tube Rear (Service Item Only)
11	532 17 50-39	Cap Axle Blk 1 50 x 1 00
--	532 14 43-34	Sealant, Tire (10 oz. Tube)

NOTE: All component dimensions given in U.S. inches
1 inch = 25.4 mm

REPAIR PARTS

TRACTOR - MODEL NO. YTH2148 (LO21H48J), PRODUCT NO. 954 57 20-35
ENGINE

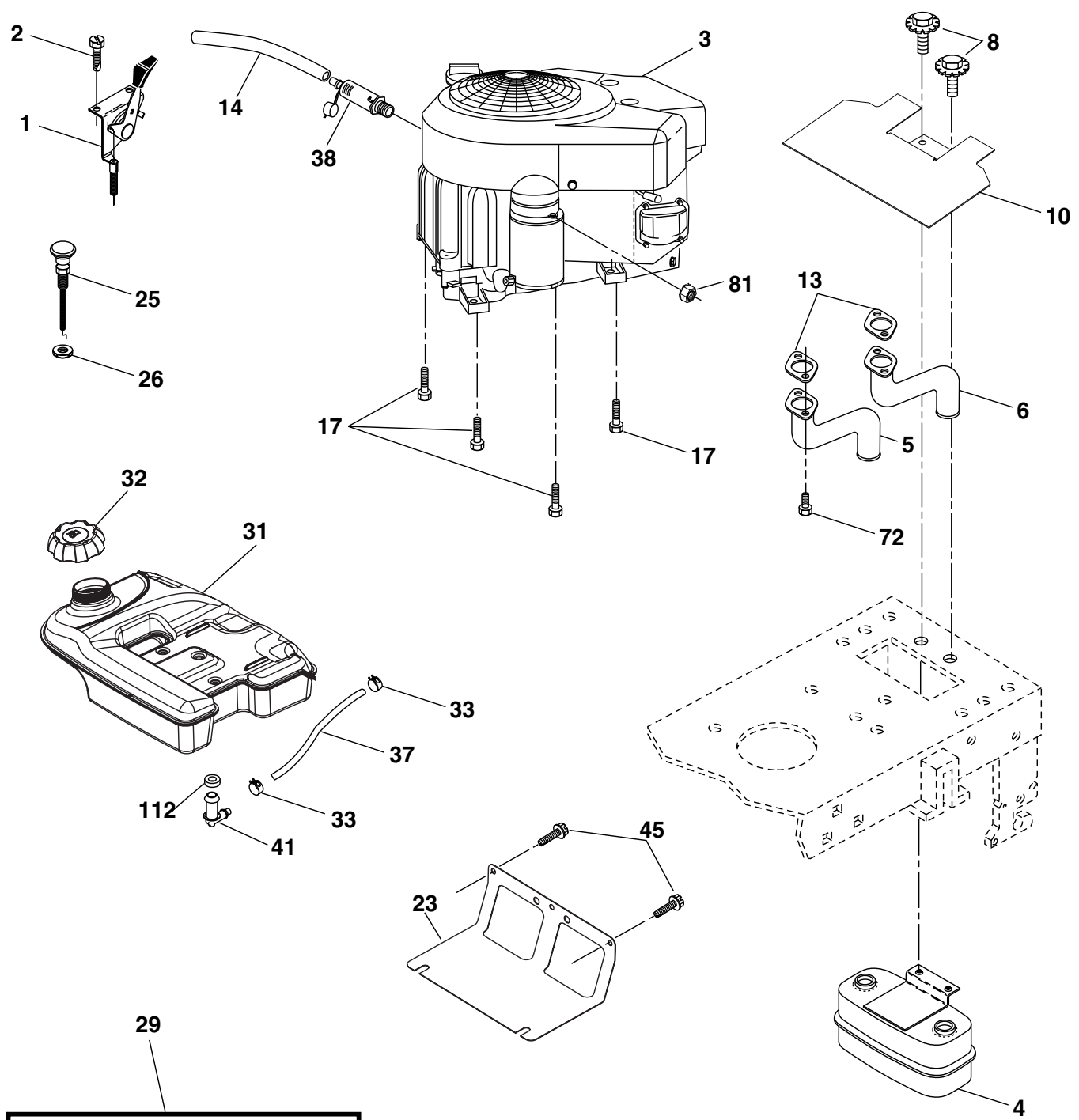

OPTIONAL EQUIPMENT
Spark Arrester

engine-bs.van2cyl_16

KEY NO.	PART NO.	DESCRIPTION
1	532 17 07-71	Control Throttle
2	817 72 04-08	Screw Hex Thd Cut 1/4-20 x 1/2
3	-----	Engine Briggs 385777 (Order Parts From Engine Manufacturer)
4	532 14 97-23	Muffler
5	532 19 15-48	Exhaust Tube LH
6	532 19 15-49	Exhaust Tube RH
8	532 17 18-77	Bolt 5/16-18 unc x 3/4
10	532 14 66-29	Shield Heat Muffler
13	532 16 53-91	Gasket
14	532 14 84-56	Tube Drain Oil Easy
17	817 06 06-24	Screw 3/8-16 x 1-1/2
23	532 16 98-37	Shield Browning/Debris Guard
25	532 16 17-29	Control Choke
26	873 92 06-00	Nut Keps 3/8-24 unf
29	532 13 71-80	Kit Spark Arrestor (Flat Scrn)
31	532 17 90-22	Tank Fuel
32	532 18 18-03	Cap Asm Fuel
33	532 12 34-87	Clamp Hose Black
37	532 14 21-58	Line Fuel
38	532 18 16-54	Plug Drain Oil Easy
41	532 13 92-77	Stem Tank Fuel
45	817 00 06-12	Screw Hex Wsh Thdr 3/8-16 x 3/4
72	532 18 39-06	Screw Socket Head 5/16-18 x 1
81	873 51 04-00	Nut Keps Hex 1/4-20 Starter Nut
112	532 12 49-52	Bushing

NOTE: All component dimensions given in U.S. inches
1 inch = 25.4 mm

REPAIR PARTS

TRACTOR - MODEL NO. YTH2148 (LO21H48J), PRODUCT NO. 954 57 20-35
MOWER LIFT

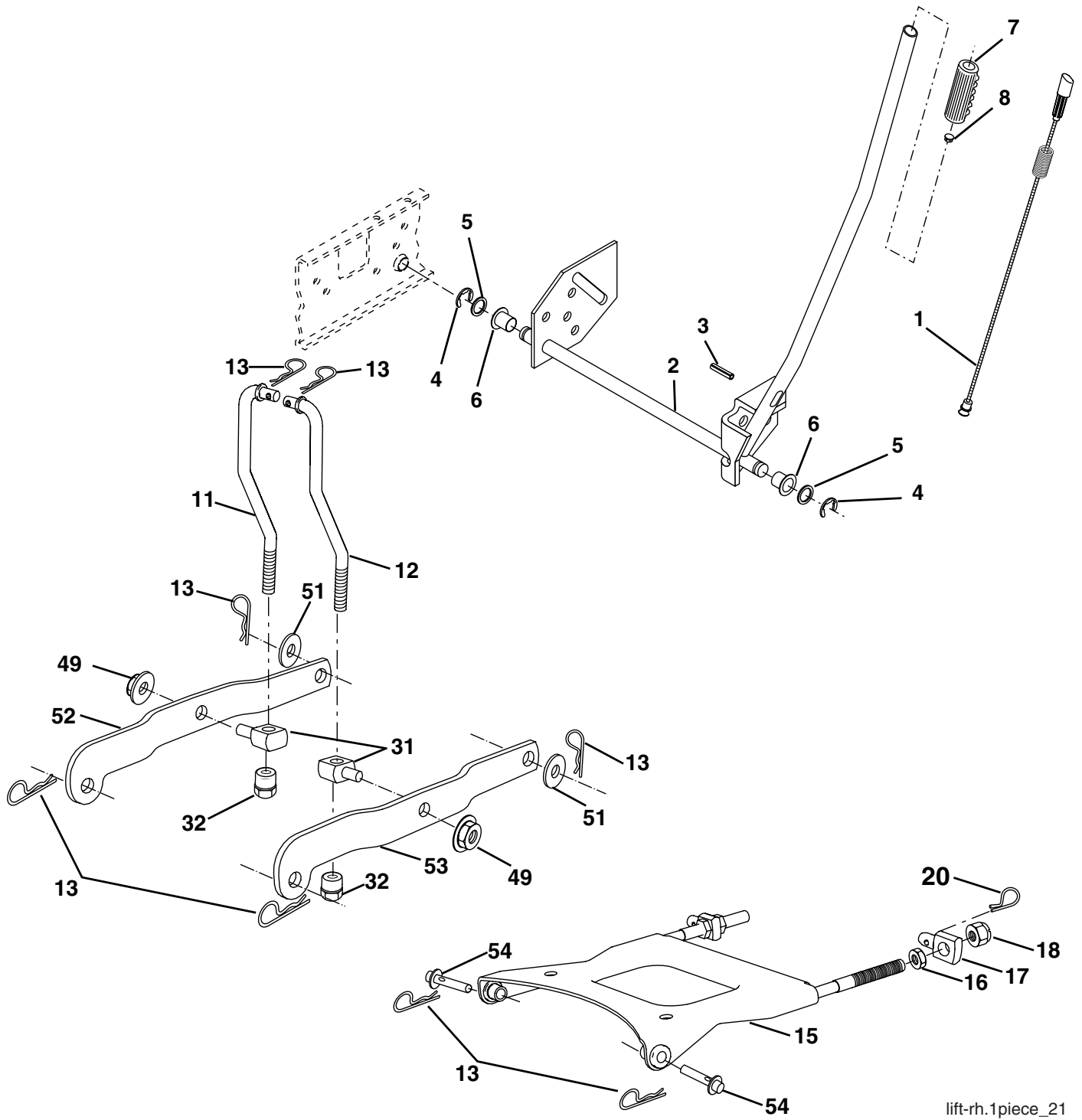

lift-rh.1piece_21

REPAIR PARTS

TRACTOR - MODEL NO. YTH2148 (LO21H48J), PRODUCT NO. 954 57 20-35
MOWER LIFT

KEY NO.	PART NO.	DESCRIPTION
1	532 15 94-60	Wire Asm Inner W/plunger 17 32
2	532 15 94-71	Shaft Asm Lift LH Inf Hgt P/L
3	532 10 57-67	Pin Groove 1 500 Zinc
4	812 00 00-02	E Ring #5133-62
5	819 21 16-21	Washer 21/32 x 1 x 21 Ga.
6	532 12 01-83	Bearing Nylon Blk 629 Id
7	532 12 56-31	Grip Handle
8	532 12 45-26	Button Plunger
11	532 17 53-70	Link Lift LH
12	532 17 53-71	Link Lift RH
13	532 12 46-70	Retainer Spring
15	532 17 55-62	Plate Asm Suspension Front
16	873 35 08-00	Nut Jam Hex 1/2-13 unc
17	532 17 56-89	Trunnion Blk Zinc
18	873 80 08-00	Nut Lock W/wsh 1/2-13 unc
20	532 16 35-52	Retainer Spring
31	532 17 62-05	Trunnion Suspension Arm
32	532 17 59-94	Nut Lift Link 7/16-20
49	532 14 52-12	Nut Hex Flange Lock
51	819 17 14-16	Washer 17/32 x 7/8 x 16 Ga.
52	532 17 53-78	Arm Suspension Rear LH
53	532 17 58-02	Arm Suspension Rear RH
54	532 17 55-60	Pin Flange

NOTE: All component dimensions given in U.S. inches
1 inch = 25.4 mm

REPAIR PARTS

TRACTOR - MODEL NO. YTH2148 (LO21H48J), PRODUCT NO. 954 57 20-35
MOWER DECK

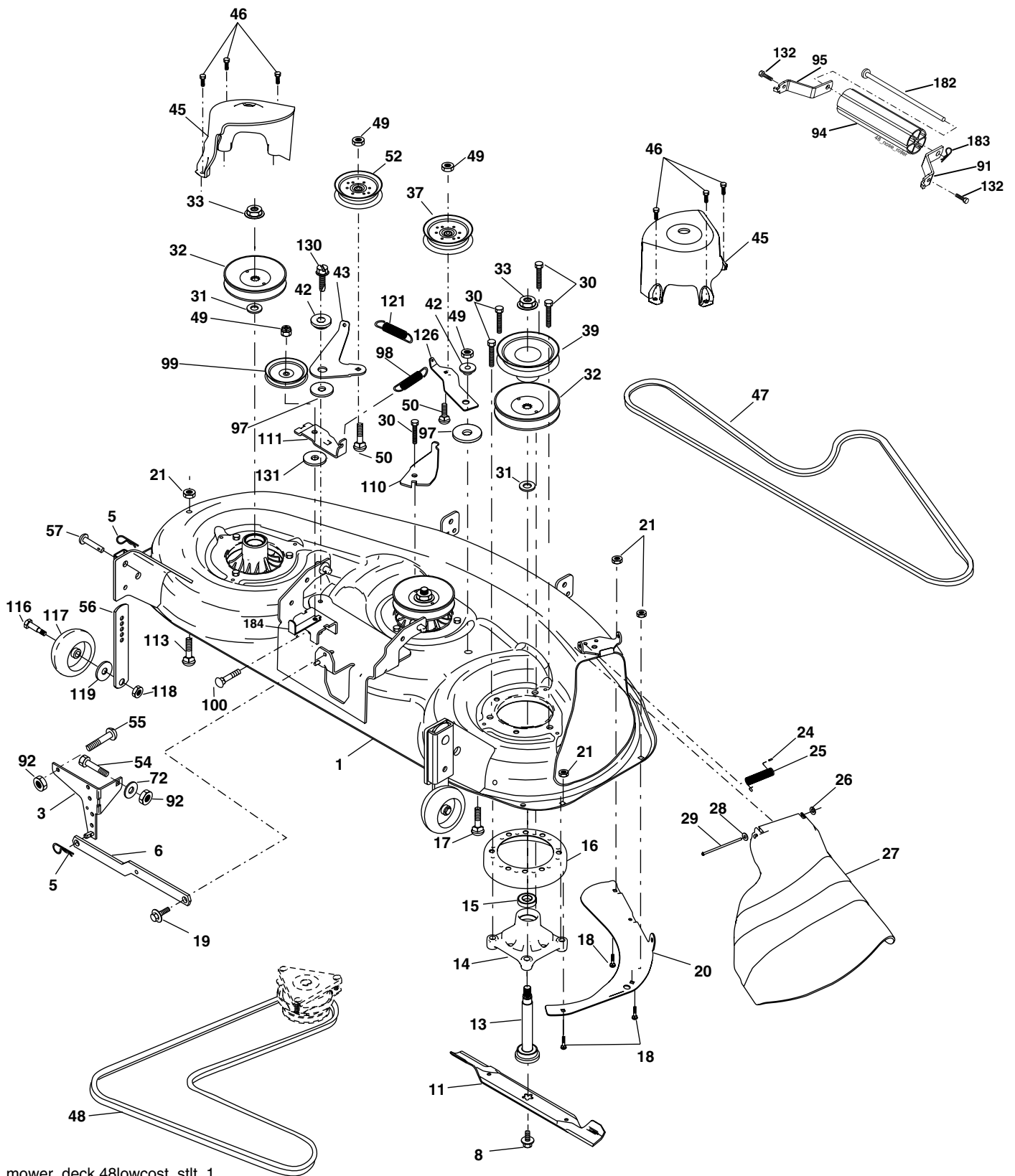

mower_deck.48lowcost_stlt_1

REPAIR PARTS

TRACTOR - MODEL NO. YTH2148 (LO21H48J), PRODUCT NO. 954 57 20-35 MOWER DECK

KEY NO.	PART NO.	DESCRIPTION	KEY NO.	PART NO.	DESCRIPTION
1	532 18 33-89	Deck Weldment Mower 48	54	874 78 06-16	Bolt Fin Hex 3/8-16 x 1
3	532 13 80-17	Bracket Asm., Sway Bar	55	872 14 06-08	Bolt Rdhd Sqnk 3/8-16 x 1
5	532 12 46-70	Retainer Spring	56	532 15 59-86	Bar Pnt Adjusting Wheel Gauge
6	532 17 80-24	Bar Sway Deck	57	532 15 69-41	Pin Head Rivet
8	532 17 43-65	Bolt, 7/16 Asm. Blade	72	819 13 13-12	Washer 13/32 x 13/16 x 12
11	532 18 00-54	Blade	91	532 18 05-35	Bracket, Asm Noseroller, RH 48
13	532 17 51-47	Shaft Asm. Mandrel Sealed	92	873 80 06-00	Nut Lock Hex w/Ins 3/8-16
14	532 17 43-58	Housing Mandrel 48"	94	532 17 60-66	Roller, Nose 48"
15	532 11 04-85	Bearing, Ball, Mandrel	95	532 18 05-34	Bracket, Asm Noseroller LH 48
16	532 17 44-93	Stripper, Mower	97	532 17 85-15	Washer Hardened
17	872 11 06-10	Bolt Rdhd Sq Neck 3/8-16 x 1.25	98	532 17 94-79	Spring Primary Drive
18	872 14 05-05	Bolt, Carriage 5/16-18 x 5/8	99	532 18 40-58	Pulley Idler "V"
19	532 13 28-27	Bolt, Hex Head, Shoulder 5/16-18	100	872 11 06-16	Bolt RDHD Sqnk 3/8-16 unc x 2
20	532 17 43-78	Baffle, Vortex Mower	110	532 17 50-16	Arm Spring Secondary
21	873 68 05-00	Nut, Crownlock 5/16-18 unc	111	532 17 46-10	Arm Spring Fixed Tension
24	532 10 53-04	Cap, Sleeve	113	872 11 05-06	Bolt Rdhd Sqnk 5/16-18 unc x 3/4
25	532 17 81-02	Spring, Torsion	116	532 18 42-19	Bolt, Shoulder
26	532 11 04-52	Nut, Push	117	532 13 39-57	Gauge Wheel
27	532 18 17-07	Shield, Deflector Mower	118	873 93 06-00	Nut, Centerlock 3/8-16 unc
28	819 11 10-16	Washer 11/32 x 5/8 x 16 Ga.	119	819 12 14-14	Washer 3/8 x 7/8 x 14 Ga.
29	532 13 14-91	Rod, Hinge	121	532 17 43-71	Spring Secondary Drive
30	532 17 39-84	Screw, Thdroll, Washer Head	126	532 17 43-72	Arm, Idler, Primary Deck
31	532 18 76-90	Washer, Spacer Mower Vented	130	817 00 06-16	Screw 3/8-16 x 1.0
32	532 17 34-36	Pulley, Mandrel	131	819 13 16-06	Washer 13/32 x 1 x 6 Ga.
33	532 17 83-42	Nut, Flg. Top Lock Cntr. 9/16	132	817 00 06-12	Screw 3/8-16 x 3/4
36	819 13 13-16	Washer 13/32 x 13/16 x 16 Ga.	182	532 17 91-27	Rod Roller Nose
37	532 17 79-68	Pulley, Idler, Flat	183	532 16 35-52	Retainer Spring
39	532 17 43-75	Pulley, Idler, Driven	184	532 17 39-79	Keeper Belt Idler
42	532 12 20-52	Spacer, Retainer	--	532 17 43-57	Mandrel Assembly (Includes Housing, Shaft and Shaft Hardware Only-Pulley Not Included)
43	532 17 43-73	Arm, Idler Secondary	--	532 18 99-06	Replacement Mower, Complete (Std Deck-Order Separately Nose Roller Components Key Nos. 91, 94, 95, 132, 182-183)
45	532 18 08-06	Cover, Mandrel Deck			
46	532 13 77-29	Screw, Thdroll. 1/4-20 x 5/8			
47	532 18 08-08	V-Belt, Mower, Secondary			
48	532 17 43-68	V-Belt, Mower, Primary			
49	839 00 06-00	Nut, Lock 3/8-16 unc			
50	872 11 06-12	Bolt, Carriage 3/8-16 x 1-1/2 Gr. 5			
52	532 17 58-20	Pulley Idler Flat 46 Pri. Drive			

NOTE: All component dimensions given in U.S. inches
1 inch = 25.4 mm